

**MILLER®**  
**EDGE™**  
**FALL PROTECTION SYSTEM**

The first and only cost-effective anchorage solution to protect workers engaged in leading edge deck construction.



Living on **The Edge**

# MILLER® **EDGE** FALL PROTECTION

The Miller Edge Fall Protection System is a portable engineered anchorage solution designed to protect decking crews from fall hazards. The Miller Edge reduces the need for a safety monitor or a temporary cable lifeline system on leading edge deck construction.

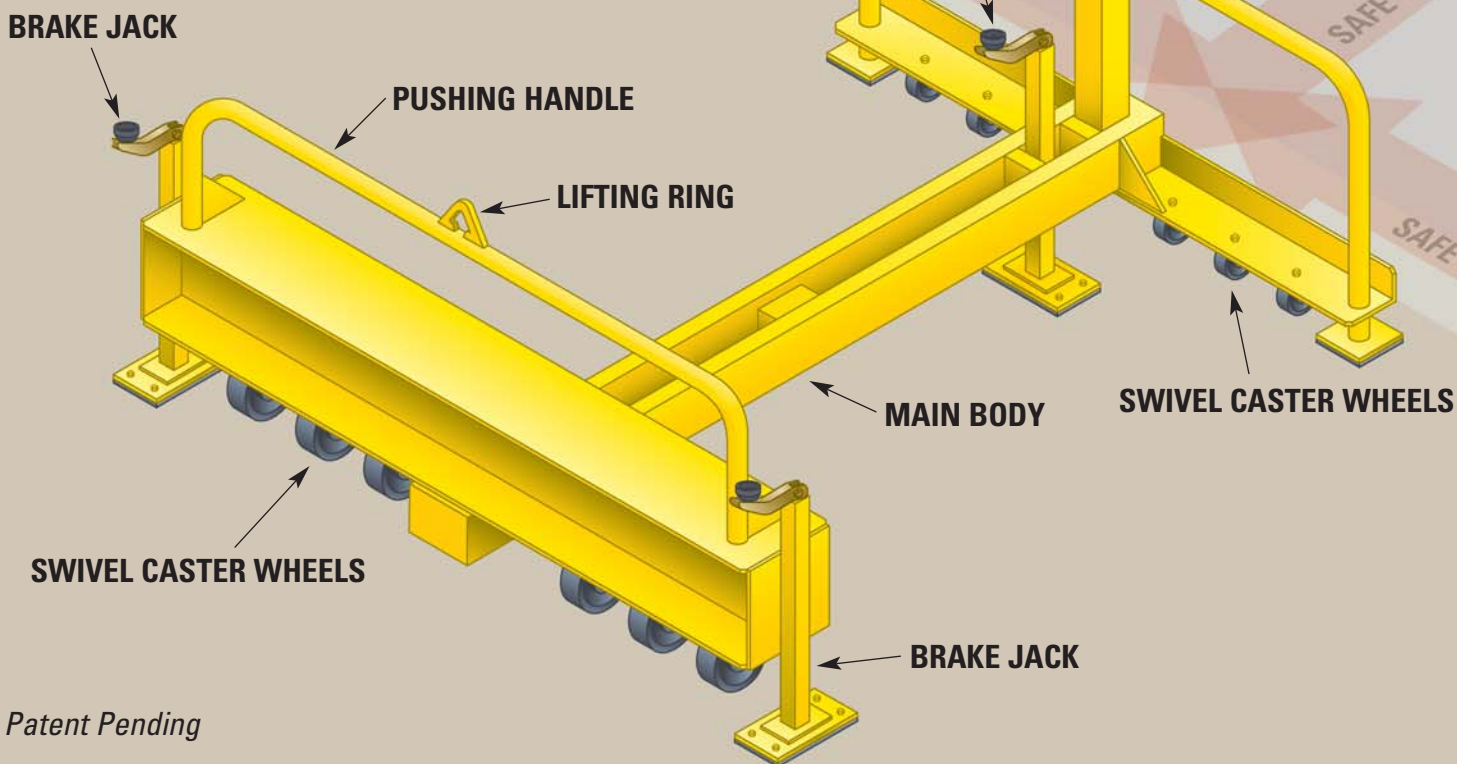
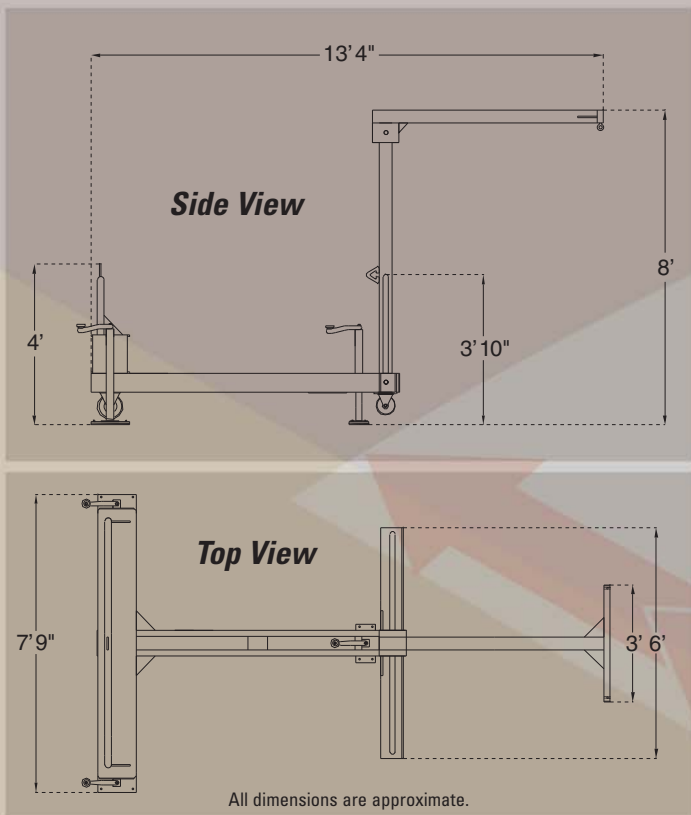

Patent Pending

# TECTION SYSTEM

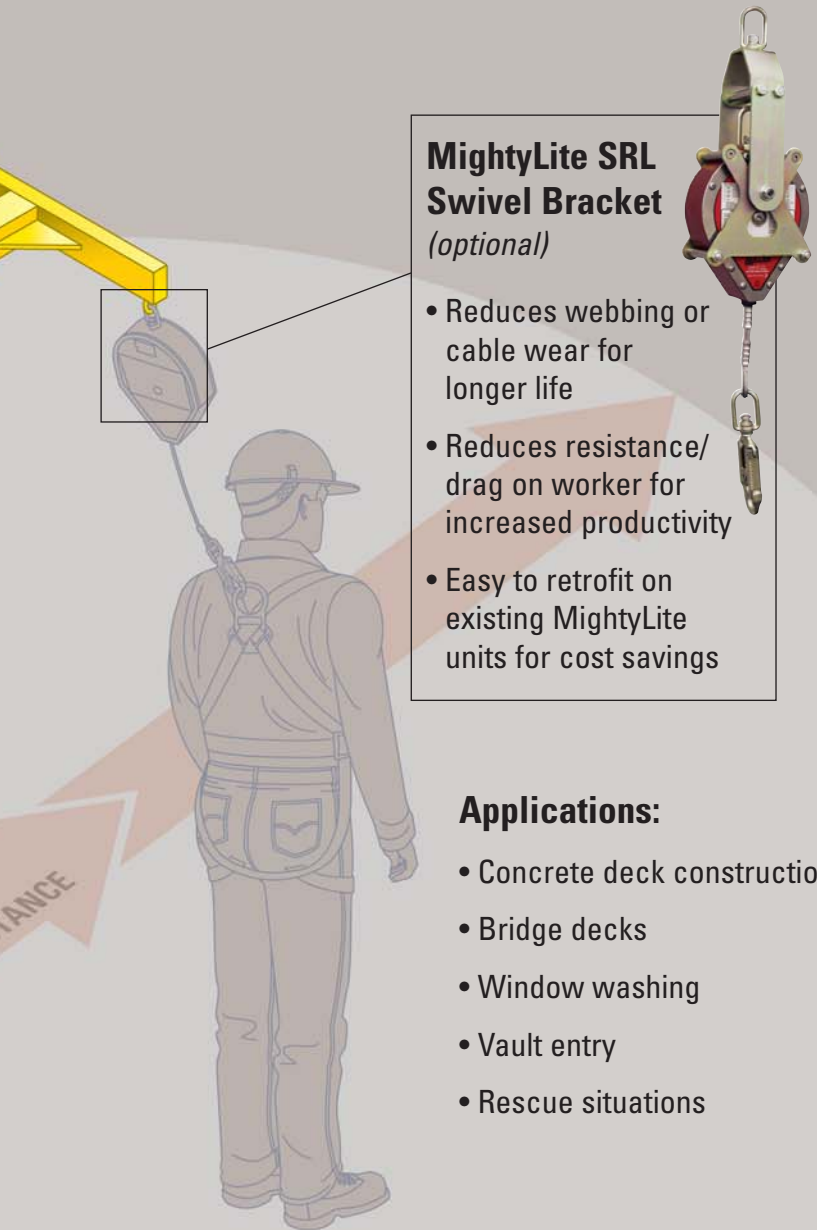

## MightyLite SRL Swivel Bracket (optional)

- Reduces webbing or cable wear for longer life
- Reduces resistance/drag on worker for increased productivity
- Easy to retrofit on existing MightyLite units for cost savings

## Applications:

- Concrete deck construction
- Bridge decks
- Window washing
- Vault entry
- Rescue situations

## MILLER EDGE FALL PROTECTION SYSTEM

Model No.	Description
9081	Miller Edge Fall Protection Unit*
9082	Swivel Bracket (retrofit) for 20' and RLS 30' MightyLite SRL units
9083	Swivel Bracket (retrofit) for 50' and 65' MightyLite SRL units

\*Swivel brackets and SRLs sold separately.

**NOTE:** When using the EDGE with a MightyLite Wire Rope SRL, it is recommended that a Miller SofStop® Shock Absorber (928LS) is used between the harness back D-ring and the snap hook of the SRL.

## The Miller Edge provides...

### Mobile overhead anchor point:

- Increases worker safety by providing 100% tie-off capability in leading edge applications
- Cost-effective alternative to a safety monitoring system that provides no added value
- Reduces swing fall hazards present with fixed cable lifeline systems

### Freestanding anchor point design:

- Saves valuable man-hours since the unit is ready-to-use when placed in position. No wasted time installing temporary cable systems that could also create tripping hazards.

### Solid Althane™ wheel casters:

- Greater mobility and easy maneuverability of the unit to follow leading edge
- Unaffected by surface obstacles such as nails, nuts and bolts, etc.

### Two integral eye bolt attachment points accommodate self-retracting lifelines:

- Provides fall protection for up to two workers simultaneously

### Three-component design:

- Easy assembly/disassembly for transport and storage

### Predetermined integral lifting points:

- Allows for quick, easy crane cable attachment for lifting on/off deck

### Heavy-duty steel construction with protective enamel paint:

- Endures rugged handling and extreme weather conditions for long-life performance

### Easy access handles on front and rear:

- Provides easy maneuverability when moving unit toward the leading edge

### Redundant braking system:

- Prevents unit from moving unintentionally



# Other Innovative Miller Fall Protection Products...

Discover  
Wraparound  
Comfort



## Miller® DuraFlex® Python™ Harnesses

The Python Harness is the next generation of the patented DuraFlex Harness series. The shoulder straps are constructed of soft, cushioned tubular webbing; the lower torso straps of specially-formulated DuraFlex stretchable webbing; and the leg straps of lightweight, non-stretch webbing. In this combination, the Python Harness not only increases overall comfort, but holds its shape for ease of donning.

### MILLER DURAFLEX PYTHON HARNESSSES

Model No.	Side D-Rings	Tool Belt Loops	Leg Strap Buckles
P950	No	No	Mating
P950-4	No	No	Tongue
P950-7	Yes	No	Mating
P950-58	Yes	No	Tongue
P950-77*	Yes	Yes	Tongue

\* Also features built-in loops, removable tool belt, and 6 inch back pad.

Feel the Difference!



## Miller® Specialty DuraFlex® Harness

Miller's patented DuraFlex full-body harness stretches with every movement. Our exclusive specially-formulated elastomer webbing allows greater freedom of movement, and offers improved comfort and overall safety. It's been proven in the field — when workers wear DuraFlex Harnesses properly, they are more comfortable, safer and more productive.

### MILLER CONSTRUCTION HARNESS E650-77

Features include:

- permanently attached back pad with positioning side D-rings
- belt loops to accommodate the removable 6414N body belt

"No Annual Factory  
Recertification"\*



## Miller® MightyLite Self-Retracting Lifeline Series

Miller MightyLite Self-Retracting Lifelines are the perfect fall protection solution for any application. Select from a complete series of varying length lifelines in galvanized wire rope, stainless steel wire rope or polyester webbing (20- and 50-foot units only).

### MILLER MIGHTYLITE SELF-RETRACTING LIFELINES

Model No.	Description
RL20P	20' Polyester Webbing Unit
RL20G	20' Galvanized Wire Rope Unit
RLS30G	30' Galvanized Wire Rope Unit
RL50P	50' Polyester Webbing Unit
RL65G	65' Galvanized Wire Rope Unit
RL100G	100' Galvanized Wire Rope Unit
RL130G	130' Galvanized Wire Rope Unit
RL175G	175' Galvanized Wire Rope Unit

\* Does not apply to Canada due to CSA Z259.2.2-98 requirements.

"Arrests Free Falls  
Within Inches"



## Miller® MiniLite™ Fall Limiter

The MiniLite Fall Limiter is a self-retracting lanyard with a quick-activating braking system that limits free falls to inches. It offers up to 11 feet of working capacity and its compact design fits in the palm of your hand.

### MILLER MINILITE FL11-3

Features include a steel twist-lock carabiner and stainless steel swivel shackle.

This equipment should only be used after reading the manufacturer's instructions. Failure to follow instructions could result in serious injury or fatality.

**MILLER**  
by SPERIAN

▶ Ask the Expert ... Ask Miller.

800/873-5242  
or 814/432-2118

Fax 800/892-4078  
or Fax 814/432-2415

www.millerfallprotection.com



For more information or to place an order,  
please contact your Miller® distributor:

LEDGE/0702/15M/MP