



**Dayflex**[®]
Corporation

Conexiones para Mangueras

SELLOS HIDRAULICOS

NORMAS AMERICANAS

NPTF (30° FLARE)	National Pipe Tapered for Fuel	SAE J516 /J476
NPSM (30° FLARE)	National Pipe Straight thread for Mechanical	J476
NPSF (30° FLARE)	National Pipe Straight thread for Fuels	
JIC (37° FLARE)	Joint Industrial Conference	SAE J514 /J516
SAE (45° FLARE)	Society of Automotive Engineers	
O-RING BOSS		J1926
ORFS	O-Ring Face Seal	SAE J516 /J1453
O-RING FLANGE CODE 61		SAE J518
O-RING FLANGE CODE 62		SAE J518

NORMAS EUROPEAS

BSPP (30° FLARE)	British Standard Pipe Parallel	ISO 228
BSPP (30° FLARE) O-RING	British Standard Pipe Parallel	ISO 1179-3
BSPT (30° FLARE)	British Standard Pipe Tapered	ISO 7-PT
GAZ (24° FLARE)		
DIN (24° FLARE) L.T	Deutsche Industrial Norme	DIN 20066 /3865
DIN (24° FLARE) H.T.	Deutsche Industrial Norme	DIN 20066 /3861

NORMAS JAPONESAS

JIS (30° FLARE)	Japanese Industrial Standard	JIS B 8363
KOMATSU (30° FLARE)		JIS B 8363

GUIA DIMENSIONES DE ROSCAS

TAMAÑO NOMINAL ROSCA

GUIÓN	NPT / NPS	BSP / JIS	JIC / BOSS	SAE - 45°	ORFS A. PLANO	CODIGO 61 D. EXT.	CODIGO 62 D. EXT.	DIN SERIE LIGERA	DIN SERIE PESADA	KOMATSU
-2	1/8-27	1/8-28	5/16-24	5/16-24	M14*1,5	...
-3	3/8-24	3/8-24	M12*1,5	M16*1,5	...
-4	1/4-18	1/4-19	7/16-20	7/16-20	9/16-18	M14*1,5	M18*1,5	M14*1,5
-5	1/2-20	1/2-20	M16*1,5	M20*1,5	...
-6	3/8-18	3/8-19	9/16-18	5/8-18	11/16-16	M18*1,5	M22*1,5	M18*1,5
-7	11/16-16	M22*1,5
-8	1/2-14	1/2-14	3/4-16	3/4-16	13/16-16	30.2	31.7	M22*1,5	M24*1,5	...
-10	...	5/8-14	7/8-14	7/8-14	1-14	34.0	...	M26*1,5	M30*2	M24*1,5
-12	3/4-14	3/4-14	1.1/16-14	1.1/16-14	1.3/16-12	38.1	41.3	M30*1,5	M36*2	M30*1,5
-14	1.3/16-12	1.1/2-12
-16	1-11,5	1-11	1.5/16-12	1.3/8-12	1.7/16-12	44.4	47.6	M36*2	M42*2	M33*1,5
-20	1.1/4-11,5	1.1/4-11	1.5/8-12	...	1.11/16-12	50.8	53.9	M42*2	M45*2	M36*1,5
-24	1.1/2-11,5	1.1/2-11	1.7/8-12	...	2-12	60.3	63.5	M45*2	M52*2	M42*1,5
-32	2-11,5	2-11	2.1/2-12	71.4	79.4	M52*2
-40	84.1
-48	101.6

D00110 SAE 100 R1AT /EN 853 1SN

FERRUL SIN PELADO PARA MANGUERAS CON MALLA DE ACERO

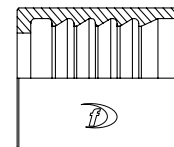

REFERENCIA	DIAMETRO MANGUERA	DIMENSIONES	
	GUION	L	D
D00110 - 03	03	27	17.5
D00110 - 04	04	30.5	20
D00110 - 05	05	33.2	21
D00110 - 06	06	32	23.3
D00110 - 08	08	34	27
D00110 - 10	10	37	30.5
D00110 - 12	12	42	34
D00110 - 16	16	50	43
D00110 - 20	20	58	52
D00110 - 24	24	66	58
D00110 - 32	32	78	72

L = Largo - D = Ancho

D00210 SAE 100 R2AT / DIN20022 2SN

FERRUL SIN PELADO PARA MANGUERAS CON MALLA DE ACERO

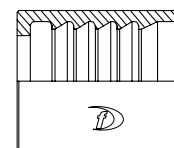

REFERENCIA	DIAMETRO MANGUERA	DIMENSIONES	
	GUION	L	D
D00210-04	04	30.5	21
D00210-05	05	32	23
D00210-06	06	32	25
D00210-08	08	34	28.5
D00210-10	10	37	32
D00210-12	12	42	36
D00210-16	16	50	45
D00210-20	20	58	56
D00210-24	24	66	63
D00210-32	32	78	75.5

L = Largo - D = Ancho

D03310 SAE 100 R2AT / EN 853 2SN

FERRUL PARA MANGUERAS CON MALLA DE ACERO

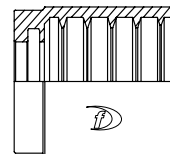

REFERENCIA	DIAMETRO MANGUERA	DIMENSIONES	
	GUION	L	D
D03310-04	04	30	22
D03310-05	05	30	24
D03310-06	06	32	26
D03310-08	08	34	29.5
D03310-10	10	37	33
D03310-12	12	42	37
D03310-16	16	51	47
D03310-20	20	57	58.5
D03310-24	24	67	67
D03310-32	32	75	80.3

L = Largo - D = Ancho

D00200 SAE 100 R2AT / EN 853 2SN

FERRUL SIN PELADO PARA MANGUERAS CON MALLA DE ACERO

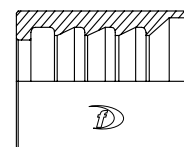

REFERENCIA	DIAMETRO MANGUERA	DIMENSIONES	
	GUION	L	D
D00200-04	04	30	21
D00200-06	06	32	25
D00200-08	08	34	30
D00200-10	10	39	33
D00200-12	12	43	37
D00200-16	16	50	46
D00200-20	20	59	56
D00200-24	24	66	62
D00200-32	32	78	75

L = Largo - D = Ancho

D00400 4SP, 4SH /12-16, R12 -16

FERRUL PARA MANGUERAS CON ESPIRAL DE ACERO

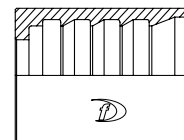

REFERENCIA	DIAMETRO MANGUERA		DIMENSIONES	
	GUION	L	D	
D00400-04	04	37.5	22	
D00400-06	06	38	26	
D00400-08	08	41	30	
D00400-10	10	43	33	
D00400-12	12	50	37	
D00400-16	16	61.5	46	
D00400-20	20	67.5	56.5	
D00400-24	24	75	65	
D00400-32	32	78	77	
D00400-40	40	83	86	

L = Largo - D = Ancho

D00401 4SH / R12 -32

FERRUL PARA MANGUERAS CON ESPIRAL DE ACERO

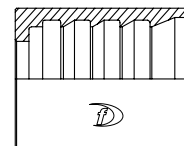

REFERENCIA	DIAMETRO MANGUERA		DIMENSIONES	
	GUION	L	D	
D00401-20	20	67.5	53	
D00401-24	24	75	61	
D00401-32	32	78	77	

L = Largo - D = Ancho

D00621 SAE 100 R13 / EN 856 R13

FERRUL PARA MANGUERAS CON ESPIRAL DE ACERO

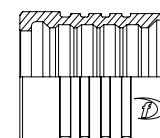

REFERENCIA	DIAMETRO MANGUERA		DIMENSIONES	
	DN	GUION	L	D
D00621-12	20	12	53	39
D00621-16	25	15	66	47.2
D00621-20	32	20	88.5	60
D00621-24	40	24	102	68
D00621-32	50	32	108	83

L = Largo - D = Ancho

D01100

FERRUL PARA MANGUERAS CON UNA MALLA DE ACERO NORMA GB/

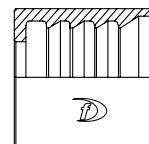

REFERENCIA	DIAMETRO MANGUERA		DIMENSIONES	
	DN	GUION	L	D
D01100-02	4	02	24	16
D01100-04	6	04	31	19
D01100-05	8	05	33	21
D01100-06	10	06	33	23
D01100-08	12	08	37	28
D01100-10	16	10	39	31
D01100-12	20	12	43	34
D01100-14	22	14	49	37
D01100-16	25	16	53	41
D01100-20	32	20	58	49
D01100-24	40	24	66	55
D01100-32	50	32	78	68.5

L = Largo - D = Ancho

D01200

FERRUL PARA MANGUERAS CON DOS MALLAS DE ACERO NORMA GB/

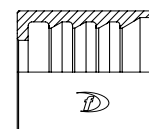

REFERENCIA	DIAMETRO MANGUERA		DIMENSIONES	
	DN	GUION	L	D
D01200-04	6	04	31	21
D01200-05	8	05	33	23
D01200-06	10	06	33	25
D01200-08	12	08	37	31
D01200-10	16	10	39	34
D01200-12	20	12	43	37
D01200-14	22	14	49	40
D01200-16	25	16	53	43
D01200-20	32	20	58	51
D01200-24	40	24	66	57
D01200-32	50	32	78	70

L = Largo - D = Ancho

D01300

FERRUL PARA MANGUERAS CON TRES MALLAS DE ACERO NORMA GB/

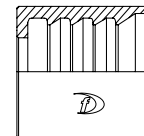

REFERENCIA	DIAMETRO MANGUERA		DIMENSIONES	
	DN	GUION	L	D
D01300-04	6	04	31	23
D01300-05	8	05	33	25
D01300-06	10	06	33	27
D01300-08	12	08	37	33
D01300-10	16	10	39	36
D01300-12	20	12	43	39
D01300-14	22	14	49	42
D01300-16	25	16	53	45
D01300-20	32	20	58	53
D01300-24	40	24	66	59
D01300-32	50	32	78	72

L = Largo - D = Ancho

D01400 R12/20 -24

FERRUL PARA MANGUERAS CON ESPIRAL DE ACERO

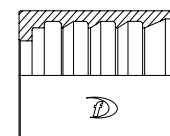

REFERENCIA	DIAMETRO MANGUERA		DIMENSIONES	
	DN	GUION	L	D
D01400-08	12	08	41	32
D01400-10	16	10	43	36
D01400-12	20	12	50	40
D01400-16	25	16	61.5	46
D01400-20	32	20	67.5	55
D01400-24	38	24	75	62
D01400-32	50	32	78	75

L = Largo - D = Ancho

D00018 SAE 100 R7

FERRUL PARA MANGUERAS CON MALLA TEXTIL

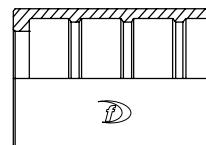

REFERENCIA	DIAMETRO MANGUERA	DIMENSIONES	
	GUION	L	D
D00018-01	01	13	10
D00018-02	02	16	12
D00018-03	03	27	14.2
D00018-04	04	29	17.6
D00018-05	05	30	19
D00018-06	06	31	21
D00018-08	08	32	25
D00018-10	10	38	28
D00018-12	12	43	33

L = Largo - D = Ancho

D00TF0

FERRUL PARA MANGUERAS TEFLON

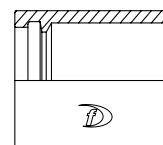

REFERENCIA	DIAMETRO MANGUERA	DIMENSIONES	
	GUION	L	D
D00TF0 - 01	01	18.5	9.2
D00TF0 - 03	03	27.5	11.9
D00TF0 - 04	04	30.7	14.5
D00TF0 - 05	05	29	16.5
D00TF0 - 06	06	32	19
D00TF0 - 08	08	34.3	24
D00TF0 - 10	10	37	26
D00TF0 - 12	12	42	30
D00TF0 - 14	14	47	34
D00TF0 - 16	16	51	37
D00TF0 - 20	20	54	49
D00TF0 - 24	24	57	55
D00TF0 - 32	32	70	69

L = Largo - D = Ancho

D00710

FERRUL PARA MANGUERAS TEFLON CORRUGADA

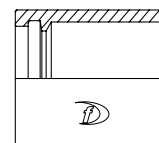

REFERENCIA	DIAMETRO MANGUERA		DIMENSIONES
	DN	GUION	L
D00710-06	10	06	28.6
D00710-08	12	08	30
D00710-12	20	12	38
D00710-16	25	16	45.9
D00710-20	32	20	54
D00710-24	40	24	57
D00710-32	50	32	69.8

L = Largo - D = Ancho

***D10211 JB/T988**

MACHO METRICO ASIENTO PLANO (ORFS)

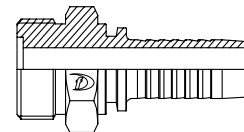

REFERENCIA	HILOS	DIAMETRO MANGUERA		DIMENSIONES		
		DN	GUION	A	C	S2
D10211-04-12	M12 x 1.5	6	04	22.5	10	14
D10211-04-14	M14 x 1.5	6	04	23.5	11	17
D10211-04-16	M16 x 1.5	6	04	23.5	11	17
D10211-05-16	M16 x 1.5	8	04	23.5	11	17
D10211-06-16	M16 x 1.5	10	06	23.5	11	17
D10211-06-18	M18 x 1.5	10	06	23.5	11	19
D10211-05-22	M22 x 1.5	8	05	27	12	22
D10211-06-22	M22 x 1.5	10	06	26	12	22
D10211-08-22	M22 x 1.5	12	08	26.5	12	22
D10211-10-27	M27 x 1.5	16	10	31.5	13	27
D10211-12-30	M30 x 1.5	20	12	33.5	14	32
D10211-12-36	M36 x 2	20	12	35.5	16	38
D10211-14-36	M36 x 2	22	14	35.5	16	38
D10211-16-39	M39 x 2	25	16	39	16	41
D10211-20-45	M45 x 2	32	20	44.5	20	46
D10211-24-52	M52 x 2	40	24	47.5	22	55
D10211-32-64	M64 x 2	50	32	52.5	27	65

NOTA

1. Para uso con mangueras trenzadas
2. Para uso con manguera espiralada la referencia cambia el ULTIMO digito

A = Alto corte conexión - C = Alto de la Cuerda - S2 = Diámetro Hexágono Cabeza

*NOTA: Para mangueras espiraladas la referencia en acoples, cambie el ultimo digito de 1 a 2.

***D20211 - D20211T** GB/T9065.3
HEMBRA METRICA ASIEN TO PLANO (ORFS)

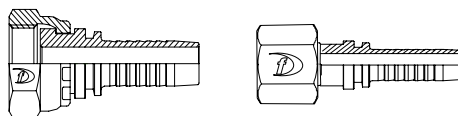

REFERENCIA	HILOS	DIAMETRO MANGUERA		DIMENSIONES		
		DN	GUION	A	C	S2
D20211-03-12	M12 x 1.25	5	03	14	8	17
D20211T-04-14	M14 x 1.5	6	04	15.5	8.5	19
D20211-05-14	M14 x 1.5	8	05	15.5	8.5	19
D20211T-04-16	M16 x 1.5	6	04	16.5	8	22
D20211T-05-16	M16 x 1.5	8	05	16.5	8	22
D20211T-06-16	M16 x 1.5	10	06	16.5	8	22
D20211T-05-18	M18 x 1.5	8	05	17.5	8	24
D20211T-06-18	M18 x 1.5	10	06	17.5	8	24
D20211T-06-20	M20 x 1.5	10	06	16	10	24
D20211T-08-20	M20 x 1.5	12	08	18.5	10	27
D20211T-06-22	M22 x 1.5	10	06	16	10	27
D20211T-08-22	M22 x 1.5	12	08	18.5	10	27
D20211T-08-24	M24 x 1.5	12	08	16.5	11	30
D20211T-10-24	M24 x 1.5	16	10	20.5	10.5	30
D20211T-08-27	M27 x 1.5	12	08	18.5	10	32
D20211T-10-27	M27 x 1.5	16	10	19.5	10	32
D20211T-12-30	M30 x 1.5	20	12	21.5	11	36
D20211T-14-36	M36 x 2	22	14	20	13	41
D20211T-16-39	M39 x 2	25	16	23.5	13	46
D20211T-20-42	M42 x 2	32	20	26	15	50
D20211T-20-45	M45 x 2	32	20	25	15	55
D20211T-24-52	M52 x 2	40	24	25	17	60
D20211T-28-60	M60 x 2	45	28	26	20	70
D20211T-32-64	M64 x 2	50	32	26	23	75

NOTA

1. Para uso con mangueras trenzadas
2. Para uso con manguera espiralada la referencia cambia el ULTIMO digito

A = Alto corte conexión - C = Alto de la Cuerda - S2 = Diámetro Hexágono Cabeza

*NOTA: Para mangueras espiraladas la referencia en acoples, cambie el ultimo digito de 1 a 2.

***D20241 - D20241T** GB/ T9065.3
HEMBRA CODO 45° METRICA ASIENTO PLANO (ORFS)

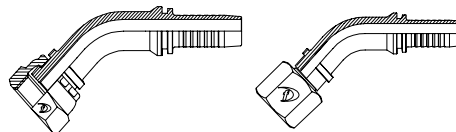

REFERENCIA	HILOS	DIAMETRO MANGUERA		DIMENSIONES			
		DN	GUIÓN	A	C	H	S2
D20241-03-12	M12 x 1.5	5	03	34.5	8.5	16	19
D20241T-04-14	M14 x 1.5	6	04	34.5	8.5	16	19
D20241-05-14	M14 x 1.5	8	05	34.5	8.5	16.5	19
D20241T-05-16	M16 x 1.5	8	05	34.5	8.5	16.5	22
D20241T-06-18	M18 x 1.5	10	06	40	8	19	24
D20241T-08-22	M22 x 1.5	12	08	48	10	23	27
D20241T-10-27	M27 x 1.5	16	10	53.5	10	23.5	32
D20241T-12-30	M30 x 1.5	20	12	58	11	25.5	36
D20241T-14-36	M36 x 2	22	14	65	13	28.5	41
D20241T-16-36	M36 x 2	25	16	66.5	13	30	41
D20241T-16-39	M39 x 2	25	16	68	13	31.5	46
D20241T-20-42	M42 x 2	32	20	81	15	37	50
D20241T-20-45	M45 x 2	32	20	82	15	38	55
D20241T-20-52	M52 x 2	32	20	83.5	17	39.5	60
D20241T-24-52	M52 x 2	40	24	86.5	17	43	60
D20241T-32-64	M64 x 2	50	32	114.5	23	53	75

NOTA

1. Para uso con mangueras trenzadas
2. Para uso con manguera espiralada la referencia cambia el ULTIMO digito

A = Alto corte conexión - C = Alto de la Cuerda - H = Longitud de Caída - S2 = Diámetro Hexágono Cabeza

*NOTA: Para mangueras espiraladas la referencia en acoples, cambie el ultimo digito de 1 a 2.

*D20291 - D20291T GB/T9065.3

HEMBRA CODO 90° METRICA ASIEN TO PLANO (ORFS)

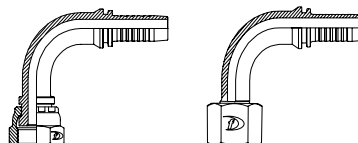

REFERENCIA	HILOS	DIAMETRO MANGUERA		DIMENSIONES			
		DN	GUION	A	C	H	S2
D20291-02-12	M12 x 1.5	4	02	25	8	26.5	17
D20291-04-12	M12 x 1.5	6	04	28.5	8	29.5	17
D20291T-04-14	M14 x 1.5	6	04	28.5	8.5	30	19
D20291-05-14	M14 x 1.5	8	05	30.5	8.5	33	19
D20291T-04-16	M16 x 1.5	6	04	28.5	8	30	22
D20291T-05-16	M16 x 1.5	8	05	30.5	8	33	22
D20291-06-16	M16 x 1.5	10	06	34	8	36.5	22
D20291T-05-18	M18 x 1.5	8	05	30.5	8	34	24
D20291-06-18	M18 x 1.5	10	06	34	8	37.5	24
D20291-08-22	M22 x 1.5	12	08	42	10	45	27
D20291T-08-24	M24 x 1.5	12	08	42	11	45	30
D20291T-10-27	M27 x 1.5	16	10	51	10	49	32
D20291T-12-30	M30 x 1.5	20	12	57	11	54	36
D20291T-14-36	M36 x 2	22	14	65	13	61	41
D20291T-16-36	M36 x 2	25	16	69	13	66	41
D20291T-16-39	M39 x 2	25	16	69	13	68	46
D20291T-20-42	M42 x 2	32	20	83	15	80	50
D20291T-20-45	M45 x 2	32	20	83	15	81	55
D20291T-20-52	M52 x 2	32	20	83	17	83	60
D20291T-24-52	M52 x 2	40	24	94	17	93	60
D20291T-28-60	M60 x 2	45	28	95	20	109	70
D20291T-32-64	M64 x 2	50	32	122	23	117	75

NOTA

1. Para uso con mangueras trenzadas
2. Para uso con manguera espiralada la referencia cambia el ULTIMO digito

A = Alto corte conexión - C = Alto de la Cuerda - H = Longitud de Caída - S2 = Diámetro Hexágono Cabeza

*NOTA: Para mangueras espiraladas la referencia en acoples, cambie el ultimo digito de 1 a 2.

***D20111 - D20111T**
HEMBRA METRICA ASIEN TO MULTISELLO

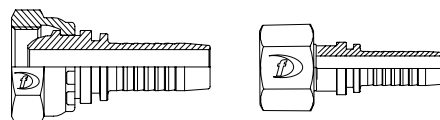

REFERENCIA	HILOS	DIAMETRO MANGUERA		DIMENSIONES		
		DN	GUION	A	C	S2
D20111-04-12	M12 x 1.5	6	04	18.5	4	17
D20111T-04-14	M14 x 1.5	6	04	19.5	4.5	19
D20111-05-14	M14 x 1.5	8	05	19.5	4.5	19
D20111T-04-16	M16 x 1.5	6	04	19.5	4.5	22
D20111T-05-16	M16 x 1.5	8	05	20	4.5	22
D20111-06-16	M16 x 1.5	10	06	20	4.5	22
D20111T-05-18	M18 x 1.5	8	05	21.5	4	24
D20111T-06-18	M18 x 1.5	10	06	21.5	4	24
D20111T-06-20	M20 x 1.5	10	06	20.5	5.5	24
D20111-08-20	M20 x 1.5	12	08	23	5.5	27
D20111T-06-22	M22 x 1.5	10	06	23	5	27
D20111T-08-22	M22 x 1.5	12	08	23.5	5	27
D20111T-08-24	M24 x 1.5	12	08	22	5.5	30
D20111-10-24	M24 x 1.5	16	10	26	5	30
D20111T-10-27	M27 x 1.5	16	10	23.5	7	32
D20111T-12-30	M30 x 1.5	20	12	26.5	7	36
D20111T-14-36	M36 x 2	22	14	26	7	41
D20111T-16-39	M39 x 2	25	16	29.5	7	46
D20111T-20-45	M45 x 2	32	20	31.5	8.5	55
D20111T-20-52	M52 x 2	32	20	33	9	60
D20111T-24-52	M52 x 2	40	24	33	9	60
D20111T-32-64	M64 x 2	50	32	35	14	75

NOTA

1. Para uso con mangueras trenzadas
2. Para uso con manguera espiralada la referencia cambia el ULTIMO digito

A = Alto corte conexión - C = Alto de la Cuerda - S2 = Diámetro Hexágono Cabeza

*NOTA: Para mangueras espiraladas la referencia en acoples, cambie el ultimo digito de 1 a 2.

*D20141 - D20141T

HEMBRA CODO 45° METRICA MULTISELLO

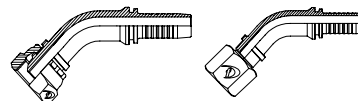

REFERENCIA	HILOS	DIAMETRO MANGUERA		DIMENSIONES			
		DN	GUION	A	C	H	S2
D20141-03-12	M12 x 1.5	5	03	40.9	4	21.2	17
D20141-04-12	M12 x 1.5	6	04	43	4	22	17
D20141T-04-14	M14 x 1.5	6	04	43.4	4.5	21.3	19
D20141-05-14	M14 x 1.5	8	05	45.5	4.5	22.2	19
D20141T-04-16	M16 x 1.5	6	04	43.7	4.5	21.4	22
D20141T-05-16	M16 x 1.5	8	05	45.8	4.5	22.5	22
D20141-06-16	M16 x 1.5	10	06	47.4	4.5	24.1	22
D20141T-05-18	M18 x 1.5	8	05	46.8	4	22.6	24
D20141T-06-18	M18 x 1.5	10	06	48.5	4	24.2	24
D20141-08-18	M18 x 1.5	12	08	52.2	4	25.7	24
D20141T-06-20	M20 x 1.5	10	06	48.2	5.5	23.9	27
D20141-08-20	M20 x 1.5	12	08	62.1	5.5	27.2	27
D20141T-06-22	M22 x 1.5	10	06	58.4	5	25.7	27
D20141T-08-22	M22 x 1.5	12	08	62.1	5	27.2	27
D20141T-08-24	M24 x 1.5	12	08	61.1	5.5	26.1	30
D20141-10-24	M24 x 1.5	16	10	75.4	5	29.6	30
D20141-10-27	M27 x 1.5	16	10	74.4	5.5	29.6	32
D20141-12-30	M30 x 2	20	12	80.9	6	33.5	36
D20141T-14-36	M36 x 2	22	14	83	7	32.64	41
D20141T-16-39	M39 x 2	25	16	88.2	7	33.95	46
D20141T-20-45	M45 x 2	32	20	99.1	8.5	38.4	55
D20141T-24-52	M52 x 2	40	24	114.1	9	43.4	60

NOTA

1. Para uso con mangueras trenzadas
2. Para uso con manguera espiralada la referencia cambia el ULTIMO digito

A = Alto corte conexión - C = Alto de la Cuerda - H = Longitud de Caída - S2 = Diámetro Hexágono Cabeza

***D20191T**

HEMBRA CODO 90° METRICA MULTISELLO

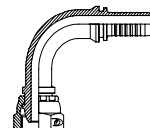

REFERENCIA	HILOS	DIAMETRO MANGUERA		DIMENSIONES			
		DN	GUION	A	C	H	S2
D20191T-04-14	M14 x 1.5	6	04	28.5	4.5	33.5	17
D20191T-04-16	M16 x 1.5	6	04	28.5	4.5	33.5	19
D20191T-05-16	M16 x 1.5	8	05	30.5	4.5	36.5	19
D20191T-04-18	M18 x 1.5	6	04	30.5	4	36.5	22
D20191T-06-18	M18 x 1.5	10	06	34	4	36.5	22
D20191T-06-20	M20 x 1.5	10	06	34	5.5	42	24
D20191T-06-22	M22 x 1.5	10	06	34	5	42	27
D20191T-08-24	M24 x 1.5	12	08	42	5.5	48.5	30
D20191T-10-27	M27 x 1.5	16	10	51	5.5	56	30
D20191T-10-30	M30 x 2	16	10	51	6	57	36
D20191T-12-30	M30 x 2	20	12	57	6	62	36
D20191T-14-36	M36 x 2	22	14	65	7	71	41
D20191T-16-39	M39 x 2	25	16	69	7	78	41
D20191T-20-45	M42 x 2	32	20	83	8.5	90	50
D20191T-20-52	M52 x 2	32	20	83	9	91	60
D20191T-24-52	M52 x 2	40	24	94	9	101	60

NOTA

1. Para uso con mangueras trenzadas
2. Para uso con manguera espiralada la referencia cambia el ULTIMO digito

A = Alto corte conexión - C = Alto de la Cuerda - H = Longitud de Caída - S2 = Diámetro Hexágono Cabeza

*NOTA: Para mangueras espiraladas la referencia en acoples, cambie el ultimo digito de 1 a 2.

***D10711** GB /F 5628
MACHO RECTO METRICO JIC (37°)

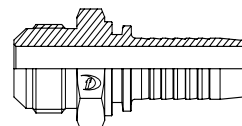

REFERENCIA	HILOS	DIAMETRO MANGUERA		DIMENSIONES		
		DN	GUION	A	C	S1
D10711-02-10	M10 x 1	4	02	23	12.5	14
D10711-03-10	M10 x 1	5	03	23	12.5	14
D10711-03-12	M12 x 1.5	5	03	26.5	15.7	14
D10711-03C-12	M12 x 1.25	5	03	24.5	14	14
D10711-04-14	M14 x 1.5	6	04	30.5	18	17
D10711-06-14	M14 x 1.5	10	06	30.5	18	17
D10711-05-16	M16 x 1.5	8	05	31.5	19	17
D10711-06-16	M16 x 1.5	10	06	31.5	19	17
D10711-06-18	M18 x 1.5	10	06	31.5	19	19
D10711-08-22	M22 x 1.5	12	08	35	19.5	22
D10711-08-24	M24 x 1.5	12	08	37	20	24
D10711-10-27	M27 x 1.5	16	10	38.5	20.5	27
D10711-12-30	M30 x 1.5	20	12	42.5	23	32
D10711-12-33	M33 x 2	20	12	45	26	36
D10711-14-36	M36 x 2	22	14	45	26	38
D10711-16-39	M39 x 2	25	16	48	27.5	41
D10711-20-42	M42 x 2	32	20	52	28.5	46
D10711-20-45	M45 x 2	32	20	52	28.5	46

NOTA

1. Para uso con mangueras trenzadas
2. Para uso con manguera espiralada la referencia cambia el ULTIMO digito

A = Alto corte conexión - **C** = Alto de la Cuerda - **S1** = Diámetro Hexágono

*NOTA: Para mangueras espiraladas la referencia en acoples, cambie el ultimo digito de 1 a 2.

***D20711 - D20711T** GB/T 9065.1
HEMBRA RECTA METRICA ASIEN TO CONICO JIC (37°)

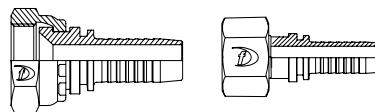

REFERENCIA	HILOS	DIAMETRO MANGUERA		DIMENSIONES		
		DN	GUION	A	C	S2
D20711-03-12	M12 x 1.5	5	03	14	10	17
D20711T-04-14	M14 x 1.5	6	04	15.5	8.5	19
D20711-05-14	M14 x 1.5	8	05	15.5	8.5	19
D20711T-04-16	M16 x 1.5	6	04	16.5	8	22
D20711T-05-16	M16 x 1.5	8	05	16.5	8	22
D20711-06-16	M16 x 1.5	10	06	16	8	22
D20711T-05-18	M18 x 1.5	8	05	16	8	22
D20711T-06-18	M18 x 1.5	10	06	17.5	10	24
D20711T-06-20	M20 x 1.5	10	06	16	10	24
D20711-08-20	M20 x 1.5	13	08	18.5	10	27
D20711T-06-22	M22 x 1.5	10	06	16	10	27
D20711T-08-22	M22 x 1.5	12	08	18.5	10	27
D20711-10-22	M22 x 1.5	16	10	19.5	10	27
D20711T-08-24	M24 x 1.5	12	08	16.5	11	30
D20711T-10-27	M27 x 1.5	16	10	19.5	11	32
D20711-12-27	M27 x 1.5	19	12	21.5	11	32
D20711T-10-30	M30 x 1.5	16	10	18.5	11	36
D20711T-12-30	M30 x 1.5	20	12	21.5	11	36
D20711T-12-33	M33 x 1.5	20	12	20	13	41
D20711T-12-36	M36 x 2	20	12	20	14	41
D20711T-14-36	M36 x 2	22	14	20	14	41
D20711T-16-36	M36 x 2	25	16	23	14	41
D20711T-16-39	M39 x 2	25	16	23.5	14	46
D20711T-16-42	M42 x 2	25	16	23.5	15	50
D20711T-20-42	M42 x 2	32	20	26	15	50
D20711T-20-45	M45 x 2	32	20	25	15	55
D20711T-24-52	M52 x 2	38	24	25	17	60

NOTA

1. Para uso con mangueras trenzadas
2. Para uso con manguera espiralada la referencia cambia el ULTIMO digito

A = Alto corte conexión - C = Alto de la Cuerda - S2 = Diámetro Hexágono Cabeza

*NOTA: Para mangueras espiraladas la referencia en acoples, cambie el ultimo digito de 1 a 2.

***D20741 - D20741T** GB/T 9065.1
HEMBRA CODO 45° METRICA ASIENTO JIC (37°)

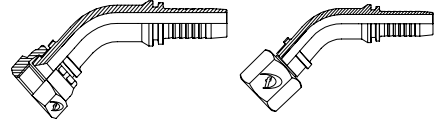

REFERENCIA	HILOS	DIAMETRO MANGUERA		DIMENSIONES			
		DN	GUION	A	C	H	S2
D20741T-04-14	M14 x 1.5	6	04	35	8.5	16.5	19
D20741T-05-16	M16 x 1.5	8	05	35	8	17	22
D20741T-06-18	M18 x 1.5	10	06	40	10	19	24
D20741T-08-22	M22 x 1.5	12	08	50	10	23	27
D20741T-10-27	M27 x 1.5	16	10	54	11	24	32
D20741T-12-30	M30 x 1.5	20	12	58.5	11	26	36
D20741T-12-33	M33 x 2	20	12	58.5	13	26	41
D20741T-16-33	M33 x 2	25	16	66	13	29.5	41
D20741T-14-36	M36 x 2	22	14	66	14	29.5	41
D20741T-16-36	M36 x 2	25	16	67.5	14	31	41
D20741T-16-39	M39 x 2	25	16	68	14	31.5	46
D20741T-20-45	M45 x 2	32	20	83	15	39	55
D20741T-24-52	M52 x 2	40	24	86	17	42.5	60

NOTA

1. Para uso con mangueras trenzadas
2. Para uso con manguera espiralada la referencia cambia el ULTIMO digito

A = Alto corte conexión - C = Alto de la Cuerda - H = Longitud de Caída - S2 = Diámetro Hexágono Cabeza

***D20791 - D20791T** GB/T 9065.1
HEMBRA CODO 90° METRICA ASIENTO JIC (37°)

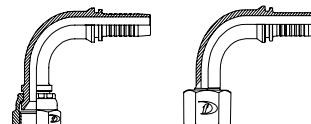

REFERENCIA	HILOS	DIAMETRO MANGUERA		DIMENSIONES			
		DN	GUION	A	C	H	S2
D20791-04-12	M12 x 1.25	6	04	28.5	9	30	17
D20791-04-12	M12 x 1.5	6	04	28.5	10	30	17
D20791T-04-14	M14 x 1.5	6	04	28.5	8.8	30	19
D20791T-04-16	M16 x 1.5	6	04	28.5	8	30	22
D20791T-05-16	M16 x 1.5	8	05	30.5	8	33	22
D20791T-06-18	M18 x 1.5	10	06	34	10	37.5	24
D20791T-08-22	M22 x 1.5	12	08	42	10	45	27
D20791-10-22	M22 x 1.5	16	10	51	10	51	27
D20791T-10-27	M27 x 1.5	16	10	51	11	49	32
D20791T-12-30	M30 x 1.5	20	12	57	11	54	36
D20791T-12-33	M33 x 2	20	12	57	13	63.5	41
D20791-16-33	M33 x 2	25	16	69	13	69	41
D20791T-12-36	M36 x 2	20	12	57	14	56	41
D20791T-14-36	M36 x 2	22	14	65	14	62	41
D20791T-16-39	M39 x 2	25	16	69	14	68	46
D20791T-20-45	M45 x 2	32	20	83	15	83	55
D20791T-20-52	M52 x 2	32	20	83	17	83	60
D20791T-24-52	M52 x 2	40	24	94	17	93	60

NOTA

1. Para uso con mangueras trenzadas
2. Para uso con manguera espiralada la referencia cambia el ULTIMO digito

A = Alto corte conexión - C = Alto de la Cuerda - H = Longitud de Caída - S2 = Diámetro Hexágono Cabeza

*NOTA: Para mangueras espiraladas la referencia en acoples, cambie el ultimo digito de 1 a 2.

*D10811L

MACHO RECTO METRICO CONO 45°

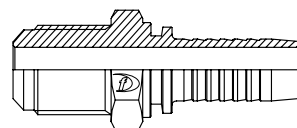

REFERENCIA	HILOS	DIAMETRO MANGUERA		DIMENSIONES		
		DN	GUION	A	C	S1
D10811L-04-12	M12 x 1.5	6	04	46	34	17
D10811L-04A-12	M12 x 1	6	04	44.5	32.5	17
D10811L-04-14	M14 x 1.5	6	04	46	34	17
D10811L-06-14	M14 x 1.5	10	06	46.5	34	17
D10811L-04-16	M16 x 1.5	6	04	46.5	41	19
D10811L-06-16	M16 x 1.5	10	06	46.5	36	22
D10811L-06-20	M20 x 1.5	10	06	57	40	24
D10811L-08-20	M20 x 1.5	12	08	57.5	40	27
D10811L-08-22	M22 x 1.5	12	08	62.5	45	27

NOTA

1. Para uso con mangueras trenzadas
2. Para uso con manguera espiralada la referencia cambia el ULTIMO digito

A = Alto corte conexión - C = Alto de la Cuerda - S1 = Diámetro Hexágono

***D10411** ISO 8434-1 - DIN 3861

MACHO METRICO RECTO ASIEN TO 24° SERIE LIVIANA

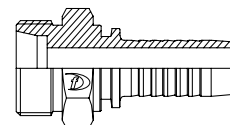

REFERENCIA	HILOS	DIAMETRO MANGUERA		DIMENSIONES		
		GUION	TUBO D.E.	A(mm)	C(mm)	S1
D10411-04-12	M12 x 1.5	04	6	26	13	14
D10411-04-14	M14 x 1.5	04	8	27	13	17
D10411-05-14	M14 x 1.5	05	8	27	13	17
D10411-04-16	M16 x 1.5	04	10	27	13.5	17
D10411-05-16	M16 x 1.5	05	10	27	13.5	17
D10411-06-16	M16 x 1.5	06	10	27	13.5	17
D10411-05-18	M18 x 1.5	05	12	28	13.5	19
D10411-06-18	M18 x 1.5	06	12	28	13.5	19
D10411-06-22	M22 x 1.5	06	15	29	14	22
D10411-08-22	M22 x 1.5	08	15	30	14	22
D10411-08-26	M26 x 1.5	08	18	32	15	27
D10411-10-26	M26 x 1.5	10	18	34	15	27
D10411-10-27	M27 x 1.5	10	18	34	15	27
D10411-10-30	M30 x 1.5	10	22	38	18	32
D10411-12-30	M30 x 1.5	12	22	38	18	32
D10411-16-36	M36 x 1.5	16	28	39	18	36
D10411-20-45	M45 x 1.5	20	35	40	18	46
D10411-24-52	M52 x 1.5	24	42	42	19	55

NOTA

1. Para uso con mangueras trenzadas
2. Para uso con manguera espiralada la referencia cambia el ULTIMO digito

A = Alto corte conexión - C = Alto de la Cuerda - S1 = Diámetro Hexágono

*NOTA: Para mangueras espiraladas la referencia en acoples, cambie el ultimo digito de 1 a 2.

***D20411 - D20411T** ISO 12151-2 - DIN 3865
HEMBRA METRICA CON O-RING ASIENTO A 24° SERIE LIGERA

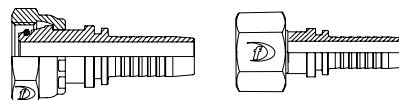

REFERENCIA	HILOS	DIAMETRO MANGUERA		DIMENSIONES			
		GUION	TUBO D.E.	O RING	A	C	S2
D20411t-04-12	M12 x 1.5	04	6	O04.5x1.5	26	2.5	17
D20411T-04-14	M14 x 1.5	04	8	O06.5x1.5	27	2	17
D20411-06-14	M14 x 1.5	06	8	O06.5x1.5	27	2	17
D20411T-04-16	M16 x 1.5	04	10	O08.0x1.5	28	2	19
D20411T-05-16	M16 x 1.5	05	10	O08.0x1.5	28	2	19
D20411T-06-16	M16 x 1.5	06	10	O08.0x1.5	28	2	19
D20411T-05-18	M18 x 1.5	05	12	O10.0x1.5	28	2.5	22
D20411T-06-18	M18 x 1.5	06	12	O10.0x1.5	29	2.5	22
D20411T-06-22	M22 x 1.5	06	15	O12.0x2.0	30	2.5	27
D20411T-08-22	M22 x 1.5	08	15	O12.0x2.0	31	2.5	27
D20411T-10-22	M22 x 1.5	10	15	O12.0x2.0	33	2.5	27
D20411T-10-26	M26 x 1.5	10	18	O15.0x2.0	33	3.5	32
D20411T-12-30	M30 x 2	12	22	O20.0x2.0	37	4	36
D20411T-16-36	M36 x 2	16	28	O26.0x2.0	37	4	41
D20411T-16-45	M45 x 2	16	35	O32.0x2.5	41	5	55
D20411T-20-45	M45 x 2	20	35	O32.0x2.5	42	5	55
D20411T-20-52	M52 x 2	20	42	O38.0x2.5	44	5.5	60
D20411T-24-52	M52 x 2	24	42	O38.0x2.5	44	5.5	60

NOTA

1. Para uso con mangueras trenzadas
2. Para uso con manguera espiralada la referencia cambia el ULTIMO digito

A = Alto corte conexión - **C =** Alto de la Cuerda - **S2 =** Diámetro Hexágono Cabeza

*NOTA: Para mangueras espiraladas la referencia en acoples, cambie el ultimo digito de 1 a 2.

*D20441T ISO 12151-2 - DIN 3865

HEMBRA CODO 45° METRICO ASIEN TO 24° SERIE LIGERA

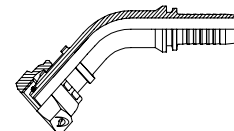

REFERENCIA	HILOS	DIAMETRO MANGUERA		TUBO D.E.	O RING	DIMENSIONES			
		DN	GUION			A	C	H	S2
D20441T-04-14	M14 x 1.5	6	04	8	O06.5x1.5	37	2	19	19
D20441T-05-16	M16 x 1.5	8	05	10	O08.0x1.5	37	2	19.5	22
D20441T-06-16	M16 x 1.5	10	06	10	O08.0x1.5	42	2	21	22
D20441T-05-18	M18 x 1.5	8	05	12	O10.0x1.5	37	2.5	19.5	22
D20441T-06-18	M18 x 1.5	10	06	12	O10.0x1.5	42	2.5	21	24
D20441T-05-22	M22 x 1.5	8	05	15	O12.0x2.0	39	2.5	21.5	27
D20441T-06-22	M22 x 1.5	10	06	15	O12.0x2.0	44	2.5	23	27
D20441T-08-22	M22 x 1.5	12	08	15	O12.0x2.0	51	2.5	26	27
D20441T-08-26	M26 x 1.5	12	08	18	O15.0x2.0	51.5	2.5	26.5	32
D20441T-10-26	M26 x 1.5	16	10	18	O15.0x2.0	59	2.5	29	32
D20441T-12-26	M26 x 1.5	20	12	18	O15.0x2.0	63.5	2.5	31	32
D20441T-10-27	M27 x 1.5	16	10	18	O15.0x2.0	59	2.5	29	32
D20441T-12-27	M27 x 1.5	20	12	18	O15.0x2.0	63.5	2.5	31	32
D20441T-10-30	M30 x 2	16	10	22	O20.0x2.0	59.5	4	29.5	36
D20441T-12-30	M30 x 2	20	12	22	O20.0x2.0	64	4	31.5	36
D20441T-12-36	M36 x 2	20	12	28	O26.0x2.0	66	4	33.5	41
D20441T-14-36	M36 x 2	22	14	28	O26.0x2.0	72	4	35.5	41
D20441T-20-45	M45 x 2	32	20	35	O32.0x2.5	88	5	44	55
D20441T-20-52	M52 x 2	32	20	42	O38.0x2.5	90.5	5.5	46.5	60
D20441T-24-52	M52 x 2	40	24	42	O38.0x2.5	113.5	5.5	50	60

NOTA

1. Para uso con mangueras trenzadas
2. Para uso con manguera espiralada la referencia cambia el ULTIMO digito

A = Alto corte conexión - C = Alto de la Cuerda - H = Longitud de Caída - S2 = Diámetro Hexágono Cabeza

*NOTA: Para mangueras espiraladas la referencia en acoples, cambie el ultimo digito de 1 a 2.

*D20491 - D20491T ISO 12151-2 - DIN 3865

HEMBRA CODO 90° METRICO ASIEN TO 24° SERIE LIGERA

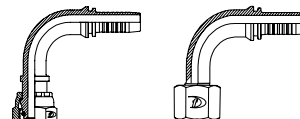

REFERENCIA	HILOS	DIAMETRO MANGUERA		TUBO D.E.	O RING	DIMENSIONES			
		GUION				A	C	H	S2
D20491-04-12	M12 x 1.25	04		8	O06.5x1.5	28.5	2	33.5	17
D20491-04-12	M12 x 1.5	04		8	O06.5x1.5	28.5	2	33.5	17
D20491T-04-14	M14 x 1.5	04		8	O06.5x1.5	28.5	2	33.5	17
D20491T-04-16	M16 x 1.5	04		10	O08.0x1.5	28.5	2	33.5	19
D20491T-05-16	M16 x 1.5	05		10	O08.0x1.5	30.5	2	36.5	19
D20491T-06-16	M16 x 1.5	06		10	O08.0x1.5	34	2	40	19
D20491T-05-18	M18 x 1.5	05		12	O10.0x1.5	30.5	2.5	36.5	22
D20491T-06-18	M18 x 1.5	06		12	O10.0x1.5	34	2.5	40	22
D20491T-06-22	M22 x 1.5	06		15	O12.0x2.0	34	2.5	43	27
D20491T-08-22	M22 x 1.5	08		15	O12.0x2.0	42	2.5	49.5	27
D20491T-10-26	M26 x 1.5	10		18	O15.0x2.0	51	3.5	56	32
D20491T-10-30	M30 x 2	10		22	O20.0x2.0	51	4	57	36
D20491T-12-30	M30 x 2	12		22	O20.0x2.0	57	4	62	36
D20491T-12-36	M36 x 2	12		28	O26.0x2.0	57	4	65	41
D20491T-16-45	M45 x 2	16		35	O32.0x2.5	69	5	78	55
D20491T-20-45	M45 x 2	20		35	O32.0x2.5	83	5	90	55
D20491T-20-52	M52 x 2	20		42	O38.0x2.5	83	5.5	93.5	60
D20491T-24-52	M52 x 2	24		42	O38.0x2.5	94	5.5	103.5	60

NOTA

1. Para uso con mangueras trenzadas
2. Para uso con manguera espiralada la referencia cambia el ULTIMO digito

A = Alto corte conexión - **C** = Alto de la Cuerda - **H** = Longitud de Caída - **S2** = Diámetro Hexágono Cabeza

*NOTA: Para mangueras espiraladas la referencia en acoples, cambie el ultimo digito de 1 a 2.

***D10511** ISO 8434-1 - DIN 3861
 MACHO METRICO RECTO ASIEN TO 24° SERIE PESADA

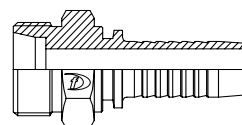

REFERENCIA	HILOS	DIAMETRO MANGUERA		DIMENSIONES		
		GUION	TUBO D.E.	A(mm)	C(mm)	S1
D10511-04-14	M14 x 1.5	04	6	24	12	14
D10511-04-16	M16 x 1.5	04	8	26.5	13.5	17
D10511-04-18	M18 x 1.5	04	10	28	14	19
D10511-05-20	M20 x 1.5	05	12	30	14	22
D10511-06-20	M20 x 1.5	06	12	30	14	22
D10511-05-22	M22 x 1.5	05	14	30	14	22
D10511-06-22	M22 x 1.5	06	14	30	14	22
D10511-08-22	M22 x 1.5	08	14	30	14	22
D10511-08-24	M24 x 1.5	08	16	30.5	14	24
D10511-10-30	M30 x 1.5	10	20	36	16	32
D10511-12-30	M30 x 1.5	12	20	36	16	32
D10511-12-36	M36 x 1.5	12	25	41	20	38
D10511-16-36	M36 x 1.5	16	25	41.5	20	38
D10511-16-42	M42 x 1.5	16	30	42	20	46
D10511-20-42	M42 x 1.5	20	30	43	20	46
D10511-24-52	M52 x 1.5	24	38	46	23	55

NOTA

1. Para uso con mangueras trenzadas
2. Para uso con manguera espiralada la referencia cambia el ULTIMO digito

A = Alto corte conexión - C = Alto de la Cuerda - S1 = Diámetro Hexágono

*NOTA: Para mangueras espiraladas la referencia en acoples, cambie el ultimo digito de 1 a 2.

*D20511T ISO 12151-2 - DIN 3865

HEMBRA METRICA RECTA ASIEN TO 24° SERIE PESADA

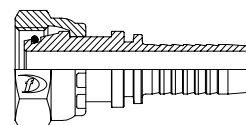

REFERENCIA	HILOS	DIAMETRO MANGUERA	TUBO D.E.	O RING	DIMENSIONES		
		GUION			A	C	S2
D20511T-04-14	M14 x 1.5	04	6	O04.5x1.5	19	2	17
D20511T-04-16	M16 x 1.5	04	8	O06.5x1.5	24	2	19
D20511T-05-16	M16 x 1.5	05	8	O06.5x1.5	24	2	19
D20511T-04-18	M18 x 1.5	04	10	O08.0x1.5	26	3	22
D20511T-06-18	M18 x 1.5	06	10	O08.0x1.5	26	3	22
D20511T-06-20	M20 x 1.5	06	12	O10.0x1.5	29	2.5	24
D20511T-06-22	M22 x 1.5	06	14	O11.0x2.0	30	2.5	27
D20511T-08-24	M24 x 1.5	08	16	O13.0x2.0	30	3.5	30
D20511T-10-30	M30 x 2	10	20	O16.3x2.4	34	3	36
D20511T-12-30	M30 x 2	12	20	O16.3x2.4	35	3	36
D20511T-14-36	M36 x 2	14	25	O20.3x2.4	36	3	41
D20511T-12-42	M42 x 2	12	30	O25.3x2.4	40	5	50
D20511T-16-42	M42 x 2	16	30	O32.0x2.5	41	5	50
D20511T-20-52	M52 x 2	20	38	O38.0x2.5	44	6.5	60
D20511T-24-52	M52 x 2	24	38	O38.0x2.5	44	6.5	60

NOTA

1. Para uso con mangueras trenzadas
2. Para uso con manguera espiralada la referencia cambia el ULTIMO digito

A = Alto corte conexión - C = Alto de la Cuerda - S2 = Diámetro Hexágono Cabeza

*NOTA: Para mangueras espiraladas la referencia en acoples, cambie el ultimo digito de 1 a 2.

*D20541T ISO 12151-2 - DIN 3865

HEMBRA CODO 45° METRICO ASIENTO 24° SERIE PESADA

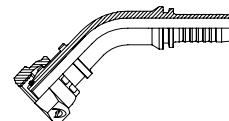

REFERENCIA	HILOS	DIAMETRO MANGUERA	TUBO D.E.	O RING	DIMENSIONES			
		GUION			A	C	H	S2
D20541T-04-14	M14 x 1.5	04	6	O04.5x1.5	37	2	19	17
D20541T-04-16	M16 x 1.5	04	8	O06.5x1.5	37	2	19	19
D20541T-05-16	M16 x 1.5	05	8	O06.5x1.5	37	2	19.5	19
D20541T-04-18	M18 x 1.5	04	10	O08.0x1.5	37	3	19	22
D20541T-06-18	M18 x 1.5	06	10	O08.0x1.5	42	3	21	22
D20541T-06-20	M20 x 1.5	06	12	O10.0x1.5	43	2.5	22	24
D20541T-06-22	M22 x 1.5	06	14	O11.0x2.0	43	2.5	22	27
D20541T-08-24	M24 x 1.5	08	16	O13.0x2.0	51.5	3.5	26.5	30
D20541T-10-24	M24 x 1.5	10	16	O13.0x2.0	59	3.5	29	30
D20541T-10-30	M30 x 2	10	20	O16.3x2.4	59.5	3	29.5	36
D20541T-12-30	M30 x 2	12	20	O16.3x2.4	64	3	31.5	36
D20541T-14-36	M36 x 2	14	25	O20.3x2.4	72	3	35.5	41
D20541T-16-42	M42 x 2	16	30	O32.0x2.5	74.5	5	38	50
D20541T-20-52	M52 x 2	20	38	O38.0x2.5	90	6.5	46	60
D20541T-24-52	M52 x 2	24	38	O38.0x2.5	113	6.5	49.5	60

NOTA

1. Para uso con mangueras trenzadas
2. Para uso con manguera espiralada la referencia cambia el ULTIMO digito

A = Alto corte conexión - C = Alto de la Cuerda - H = Longitud de Caída - S2 = Diámetro Hexágono Cabeza

*NOTA: Para mangueras espiraladas la referencia en acoples, cambie el ultimo digito de 1 a 2.

*D20591T ISO 12151-2 - DIN 3865

HEMBRA CODO 90° METRICO ASIENTO 24° SERIE PESADA

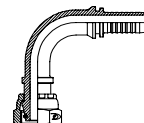

REFERENCIA	HILOS	DIAMETRO MANGUERA	TUBO D.E.	O RING	DIMENSIONES			
		GUION			A	C	H	S2
D20591T-04-14	M14 x 1.5	04	6	O04.5x1.5	28.5	2	33.5	17
D20591T-04-16	M16 x 1.5	04	8	O06.5x1.5	28.5	2	33.5	19
D20591T-05-16	M16 x 1.5	05	8	O06.5x1.5	30.5	2	36.5	19
D20591T-04-18	M18 x 1.5	04	10	O08.0x1.5	30.5	3	36.5	22
D20591T-06-18	M18 x 1.5	06	10	O08.0x1.5	34	3	36.5	22
D20591T-06-20	M20 x 1.5	06	12	O10.0x1.5	34	2.5	42	24
D20591T-06-22	M22 x 1.5	06	14	O11.0x2.0	34	2.5	42	27
D20591T-08-24	M24 x 1.5	08	16	O13.0x2.0	42	3.5	48.5	30
D20591T-10-24	M24 x 1.5	10	16	O13.0x2.0	51	3.5	56	30
D20591T-10-30	M30 x 2	10	20	O16.3x2.4	51	3	57	36
D20591T-12-30	M30 x 2	12	20	O16.3x2.4	57	3	62	36
D20591T-14-36	M36 x 2	14	25	O20.3x2.4	65	3	71	41
D20591T-16-42	M42 x 2	16	30	O32.0x2.5	69	5	77	50
D20591T-20-52	M52 x 2	20	38	O38.0x2.5	83	6.5	92.5	60
D20591T-24-52	M52 x 2	24	38	O38.0x2.5	94	6.5	102.5	60

NOTA

1. Para uso con mangueras trenzadas
2. Para uso con manguera espiralada la referencia cambia el ULTIMO digito

A = Alto corte conexión - C = Alto de la Cuerda - H = Longitud de Caída - S2 = Diámetro Hexágono Cabeza

***D50011** DIN 2353
 ESPIGA TUBO METRICA RECTA S.L. y S.P.

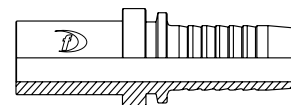

REFERENCIA	DIAMETRO MANGUERA	TUBO D.E.	DIMENSIONES	
	GUION		A	C
D50011-03-06	03	6	32	22
D50011-04-06	04	6	32	22
D50011-05-10	05	10	34	23
D50011-06-10	06	10	35	23
D50011-06-12	06	12	35	23
D50011-08-15	08	15	39	25
D50011-10-18	10	18	41	26
D50011-10-22	10	22	43	28
D50011-12-22	12	22	43	28
D50011-16-28	16	28	48	30
D50011-04-08	04	8	35	24
D50011-05-08	05	8	35	24
D50011-04-10	04	10	37	26
D50011-04-12	04	12	37	26
D50011-12-14	12	14	43	29
D50011-08-16	08	16	43	30
D50011-10-16	10	16	45	30
D50011-10-20	10	20	51	36
D50011-12-20	12	20	51	36
D50011-12-25	12	25	57	40
D50011-16-25	16	25	58	40
D50011-16-30	16	30	62	44
D50011-20-30	20	30	63	44

NOTA

1. Para uso con mangueras trenzadas
2. Para uso con manguera espiralada la referencia cambia el ULTIMO dígito

A = Alto corte conexión - C = Alto de la Cuerda

*NOTA: Para mangueras espiraladas la referencia en acoples, cambie el ultimo dígito de 1 a 2.

*D50041 DIN 2353

ESPIGA CODO 45° TUBO METRICO S.L. y S.P.

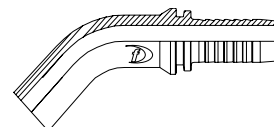

REFERENCIA	DIAMETRO MANGUERA	TUBO D.E.	DIMENSIONES		
	GUION		A	C	H
D50041-03-06	03	6	42	22	22
D50041-04-06	04	6	43.5	22	23.5
D50041-05-10	05	10	47	23	27.5
D50041-06-10	06	10	51.5	23	30.5
D50041-06-12	06	12	51.5	23	30.5
D50041-08-15	08	15	59	25	34
D50041-10-18	10	18	65.5	26	37.5
D50041-10-22	10	22	66.5	28	38.5
D50041-12-22	12	22	73	28	40.5
D50041-16-28	16	28	80.5	30	45.5
D50041-04-08	04	8	46	24	27
D50041-05-08	05	8	46	24	27.5
D50041-04-10	04	10	47.5	26	28.5
D50041-04-12	04	12	47.5	26	28.5
D50041-12-14	12	14	74.5	29	42
D50041-08-16	08	16	62.5	30	37.5
D50041-10-16	10	16	70	30	40
D50041-10-20	10	20	78.5	36	45
D50041-12-20	12	20	79.5	36	47
D50041-12-25	12	25	82.5	40	50
D50041-16-25	16	25	90.5	40	54
D50041-16-30	16	30	93.5	44	57
D50041-20-30	20	30	106.5	44	62.5

NOTA

1. Para uso con mangueras trenzadas
2. Para uso con manguera espiralada la referencia cambia el ULTIMO digito

A = Alto corte conexión - C = Alto de la Cuerda - H = Longitud de Caída

*NOTA: Para mangueras espiraladas la referencia en acoples, cambie el ultimo digito de 1 a 2.

***D50091** DIN 2353

ESPIGA CODO 90° TUBO METRICO S.L. y S.P.

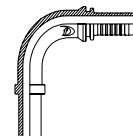

REFERENCIA	DIAMETRO MANGUERA	TUBO D.E.	DIMENSIONES		
	GUION		A	C	H
D50091-03-06	03	6	26	22	37
D50091-04-06	04	6	28.5	22	40
D50091-05-10	05	10	30.5	23	48
D50091-06-10	06	10	34	23	53.5
D50091-06-12	06	12	34	23	53.5
D50091-08-15	08	15	42	25	61
D50091-10-18	10	18	51	26	68
D50091-10-22	10	22	51	28	69
D50091-12-22	12	22	57	28	74
D50091-16-28	16	28	69	30	88
D50091-04-08	04	8	28.5	24	45
D50091-05-08	05	8	30.5	24	48
D50091-04-10	04	10	28.5	26	47
D50091-04-12	04	12	28.5	26	47
D50091-12-14	12	14	57	29	77
D50091-08-16	08	16	42	30	66
D50091-10-16	10	16	51	30	72
D50091-10-20	10	20	51	36	79
D50091-12-20	12	20	57	36	84
D50091-12-25	12	25	57	40	88
D50091-16-25	16	25	83	40	100
D50091-16-30	16	30	69	44	104
D50091-20-30	20	30	83	44	116

NOTA

1. Para uso con mangueras trenzadas
2. Para uso con manguera espiralada la referencia cambia el ULTIMO digito

A = Alto corte conexión - C = Alto de la Cuerda - H = Longitud de Caída

*NOTA: Para mangueras espiraladas la referencia en acoples, cambie el ultimo digito de 1 a 2.

*D13011

MACHO BSPT RECTO

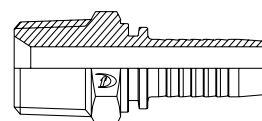

REFERENCIA	HILOS	DIAMETRO MANGUERA	DIMENSIONES		
		GUION	A	C	S1
D13011-03-02	ZG 1/8" x28	03	23.5	12	10
D13011-04-02	ZG 1/8" x28	04	23.5	14	10
D13011-04-04	ZG 1/4" x19	04	28	14	14
D13011-05-04	ZG 1/4" x19	05	28	17	14
D13011-06-04	ZG 1/4" x19	06	28	17	14
D13011-04-06	ZG 3/8" x19	04	27	17	14
D13011-06-06	ZG 3/8" x19	06	29	17	15
D13011-08-06	ZG 3/8" x19	08	31	19	15
D13011-06-08	ZG 1/2" x14	06	34.5	22	19
D13011-08-08	ZG 1/2" x14	08	35	22	19
D13011-10-08	ZG 1/2" x14	10	36	22	19
D13011-12-08	ZG 1/2" x14	12	37	27	19
D13011-08-12	ZG 3/4" x14	08	38	32	20
D13011-10-12	ZG 3/4" x14	10	39	32	20
D13011-12-12	ZG 3/4" x14	12	39	32	20
D13011-16-12	ZG 3/4" x14	16	39	32	20
D13011-12-16	ZG 1" x11	12	43	36	24
D13011-16-16	ZG 1" x11	16	45.5	41	24
D13011-20-20	ZG 1.1/4" x11	20	48	46	25
D13011-24-24	ZG 1.1/2" x11	24	48	50	25
D13011-24-32	ZG 2" x11	24	51	65	27
D13011-32-32	ZG 2" x11	32	52	65	27

NOTA

1. Para uso con mangueras trenzadas
2. Para uso con manguera espiralada la referencia cambia el ULTIMO digito

A = Alto corte conexión - C = Alto de la Cuerda - S1 = Diámetro Hexágono

*NOTA: Para mangueras espiraladas la referencia en acoples, cambie el ultimo digito de 1 a 2.

*D12611

MACHO BSP RECTO ASIENTO 30°

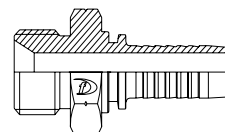

REFERENCIA	HILOS	DIAMETRO MANGUERA	DIMENSIONES		
		GUION	A	C	S1
D12611-03-02	G 1/8" x28	03	25	10	12
D12611-04-04	G 1/4" x19	04	25	12	14
D12611-06-06	G 3/8" x19	06	27.5	13.5	17
D12611-08-06	G 3/8" x19	08	28.5	13.5	19
D12611-06-08	G 1/2" x14	06	32	16	22
D12611-08-08	G 1/2" x14	08	32	16	22
D12611-08-10	G 5/8" x14	08	32.5	17.5	24
D12611-10-10	G 5/8" x14	10	33.5	17.5	24
D12611-08-12	G 3/4" x14	08	34.5	18.5	27
D12611-10-12	G 3/4" x14	10	35.5	18.5	27
D12611-12-12	G 3/4" x14	12	36.5	18.5	27
D12611-12-16	G 1" x11	12	40.5	20.5	36
D12611-16-16	G 1" x11	16	41	20.5	36
D12611-20-20	G 1.1/4" x11	20	42.5	20.5	46
D12611-20-24	G 1.1/2" x11	20	46	23	50
D12611-24-24	G 1.1/2" x11	24	46	23	50
D12611-32-32	G 2" x11	32	50.5	25.5	65

NOTA

1. Para uso con mangueras trenzadas
2. Para uso con manguera espiralada la referencia cambia el ULTIMO digito

A = Alto corte conexión - C = Alto de la Cuerda - S1 = Diámetro Hexágono

*NOTA: Para mangueras espiraladas la referencia en acoples, cambie el ultimo digito de 1 a 2.

*D22111

HEMBRA BSP RECTA MULTISELLO

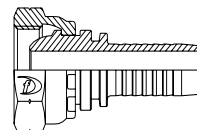

REFERENCIA	HILOS	DIAMETRO MANGUERA		DIMENSIONES		
		DN	GUION	A	C	S2
D22111-04-02	G 1/8" x28	6	04	19	2	14
D22111-03-04	G 1/4" x19	5	03	19	4	19
D22111-04-04	G 1/4" x19	6	04	19.5	4	19
D22111-05-06	G 3/8" x19	8	05	20	5	22
D22111-06-06	G 3/8" x19	10	06	20.5	5	22
D22111-08-06	G 3/8" x19	12	08	21	5	22
D22111-08-08	G 1/2" x14	12	08	23	6	27
D22111-10-08	G 1/2" x14	16	10	24	6	27
D22111-10-10	G 5/8" x14	16	10	25	8	30
D22111-12-10	G 5/8" x14	20	12	25	8	30
D22111-10-12	G 3/4" x14	16	10	26	9.5	32
D22111-12-12	G 3/4" x14	20	12	26	7.5	32
D22111-14-16	G 1" x11	22	14	26.5	11	41
D22111-16-16	G 1" x11	25	16	30.5	8	41
D22111-20-20	G 1.1/4" x11	32	20	31.5	10	50
D22111-24-24	G 1.1/2" x11	40	24	37	11.5	55
D22111-32-32	G 2" x11	50	32	34	15	70

NOTA

1. Para uso con mangueras trenzadas
2. Para uso con manguera espiralada la referencia cambia el ULTIMO digito

A = Alto corte conexión - **C** = Alto de la Cuerda - **S2** = Diámetro Hexágono Cabeza

*NOTA: Para mangueras espiraladas la referencia en acoples, cambie el ultimo digito de 1 a 2.

***D22141**

HEMBRA CODO 45° SELLO BSP MULTISELLO

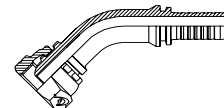

REFERENCIA	HILOS	DIAMETRO MANGUERA		DIMENSIONES			
		DN	GUION	A	C	H	S2
D22141-04-02	G 1/8" x28	6	04	34	2	16.5	14
D22141-03-04	G 1/4" x19	5	03	34	4	16.5	19
D22141-04-04	G 1/4" x19	6	04	36	4	18	19
D22141-05-06	G 3/8" x19	8	05	38	5	20.5	22
D22141-06-06	G 3/8" x19	10	06	43	5	22	22
D22141-08-06	G 3/8" x19	12	08	50	5	25	22
D22141-08-08	G 1/2" x14	12	08	50.5	6	25.5	27
D22141-10-08	G 1/2" x14	16	10	58	6	28	27
D22141-10-10	G 5/8" x14	16	10	58	8	28	30
D22141-12-10	G 5/8" x14	20	12	61.5	8	30	30
D22141-10-12	G 3/4" x14	16	10	59	9.5	29	32
D22141-12-12	G 3/4" x14	20	12	62.5	9.5	31	32
D22141-12-16	G 1" x11	20	12	65	11	33.5	41
D22141-14-16	G 1" x11	22	14	70	11	35.5	41
D22141-16-16	G 1" x11	25	16	71	11	36	41
D22141-20-20	G 1.1"/4x11	32	20	84.5	10	42.5	50
D22141-24-24	G 1.1"/2x11	40	24	91	11.5	48	55
D22141-32-32	G 2" x11	50	32	121	15	60	70

NOTA

1. Para uso con mangueras trenzadas
2. Para uso con manguera espiralada la referencia cambia el ULTIMO digito

A = Alto corte conexión - **C** = Alto de la Cuerda - **H** = Longitud de Caída - **S2** = Diámetro Hexágono Cabeza

*NOTA: Para mangueras espiraladas la referencia en acoples, cambie el ultimo digito de 1 a 2.

*D22191

HEMBRA CODO 90° SELLO BSP MULTISELLO

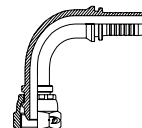

REFERENCIA	HILOS	DIAMETRO MANGUERA		DIMENSIONES			
		DN	GUION	A	C	H	S2
D22191-04-02	G 1/8" x28	6	04	30	2	38.5	14
D22191-03-04	G 1/4" x19	5	03	29	4	35	19
D22191-04-04	G 1/4" x19	6	04	32	4	33	19
D22191-05-04	G 3/8" x19	8	05	35	4	35	19
D22191-05-06	G 3/8" x19	8	05	38	5	38	22
D22191-06-06	G 3/8" x19	10	06	41.5	5	44	22
D22191-08-06	G 3/8" x19	12	08	48	5	49	22
D22191-08-08	G 1/2" x14	12	08	49	6	50	27
D22191-10-08	G 1/2" x14	16	10	55	6	58	27
D22191-10-10	G 5/8" x14	16	10	55	8	58	30
D22191-12-10	G 5/8" x14	20	12	60	8	62	30
D22191-10-12	G 3/4" x14	16	10	58.5	9.5	59	32
D22191-12-12	G 3/4" x14	20	12	61.5	9.5	64	32
D22191-14-16	G 1" x11	22	14	71.5	11	68	41
D22191-16-16	G 1" x11	25	16	76.5	11	74	41
D22191-20-20	G 1.1"/4x11	32	20	92.3	10	85.3	50
D22191-24-24	G 1.1"/2x11	40	24	109.4	11.5	108	55
D22191-32-32	G 2" x11	50	32	127	15	123.8	70

NOTA

1. Para uso con mangueras trenzadas
2. Para uso con manguera espiralada la referencia cambia el ULTIMO digito

A = Alto corte conexión - C = Alto de la Cuerda - H = Longitud de Caída - S2 = Diámetro Hexágono Cabeza

*NOTA: Para mangueras espiraladas la referencia en acoples, cambie el ultimo digito de 1 a 2.

*D22211

HEMBRA BSP RECTA ASIENTO PLANO

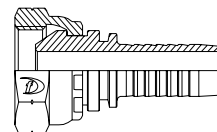

REFERENCIA	HILOS	DIAMETRO MANGUERA	DIMENSIONES		
		GUION	A(mm)	C(mm)	S2
D22211-04-04	G 1/4" x19	04	15.5	8	19
D22211-06-04	G 1/4" x19	06	16	8	19
D22211-04-06	G 3/8" x19	04	17.5	11	22
D22211-05-06	G 3/8" x19	05	17.5	11	22
D22211-06-06	G 3/8" x19	06	18	11	22
D22211-08-06	G 3/8" x19	08	18	11	22
D22211-08-08	G 1/2" x14	08	19	11	27
D22211-08-10	G 5/8" x14	08	19	11.5	27
D22211-10-10	G 5/8" x14	10	20	11.5	27
D22211-10-12	G 3/4" x14	10	20	12.5	32
D22211-12-12	G 3/4" x14	12	21	12.5	32
D22211-16-16	G 1" x11	16	25	14	41
D22211-20-20	G 1.1/4" x11	20	26	14	50
D22211-24-24	G 1.1/2" x11	24	26	17	55
D22211-32-32	G 2" x11	32	30	23	70

NOTA

1. Para uso con mangueras trenzadas
2. Para uso con manguera espiralada la referencia cambia el ULTIMO digito

A = Alto corte conexión - C = Alto de la Cuerda - S2 = Diámetro Hexágono Cabeza

*NOTA: Para mangueras espiraladas la referencia en acoples, cambie el ultimo digito de 1 a 2.

*D22241

HEMBRA CODO 45° SELLO BSP ASIENTO PLANO

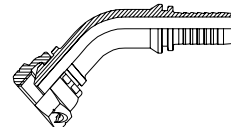

REFERENCIA	HILOS	DIAMETRO MANGUERA	DIMENSIONES			
		GUION	A	C	H	S2
D22241-04-04	G 1/4" x19	04	34.5	8	16.5	19
D22241-06-06	G 3/8" x19	06				
D22241-08-08	G 1/2" x14	08	48	11	23	27
D22241-12-12	G 3/4" x14	12				
D22241-16-16	G 1" x11	16	69	14	33	41
D22241-20-20	G 1.1/4" x11	20	83	14	39	50
D22241-24-24	G 1.1/2" x11	24	86.5	17	43	55

NOTA

1. Para uso con mangueras trenzadas
2. Para uso con manguera espiralada la referencia cambia el ULTIMO digito

A = Alto corte conexión - C = Alto de la Cuerda - H = Longitud de Caída - S2 = Diámetro Hexágono Cabeza

*D22291

HEMBRA CODO 90° SELLO BSP ASIENTO PLANO

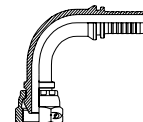

REFERENCIA	HILOS	DIAMETRO MANGUERA	DIMENSIONES			
		GUION	A	C	H	S2
D22291-04-04	G 1/4" x19	04	28.5	8	30	19
D22291-06-06	G 3/8" x19	06	34	11	37.5	22
D22291-08-08	G 1/2" x14	08	42	11	44	27
D22291-12-12	G 3/4" x14	12	57	12.5	58	32
D22291-16-16	G 1" x11	16	69	14	70.5	41
D22291-20-20	G 1.1/4" x11	20	83	14	83	50
D22291-24-24	G 1.1/2" x11	24	94	17	93.5	55

NOTA

1. Para uso con mangueras trenzadas
2. Para uso con manguera espiralada la referencia cambia el ULTIMO digito

A = Alto corte conexión - C = Alto de la Cuerda - H = Longitud de Caída - S2 = Diámetro Hexágono Cabeza

*NOTA: Para mangueras espiraladas la referencia en acoples, cambie el ultimo digito de 1 a 2.

***D22611**

HEMBRA BSP RECTA ASIENTO (30°)

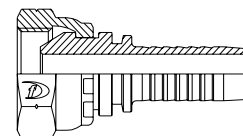

REFERENCIA	HILOS	DIAMETRO MANGUERA	DIMENSIONES		
		GUION	A	C	S2
D22611-03-02	G 1/8" x28	03	16.5	4	14
D22611-04-02	G 1/8" x28	04	16.5	4	14
D22611-04-04	G 1/4" x19	04	18.5	5.5	19
D22611-05-04	G 1/4" x19	05	19	5.5	19
D22611-06-04	G 1/4" x19	06	19	5.5	19
D22611-04-06	G 3/8" x19	04	21	6.5	22
D22611-05-06	G 3/8" x19	05	21	6.5	22
D22611-06-06	G 3/8" x19	06	21	6.5	22
D22611-06-08	G 1/2" x19	06	22	8	22
D22611-08-08	G 1/2" x14	08	22	8	27
D22611-08-10	G 5/8" x14	08	22	8.5	27
D22611-10-10	G 5/8" x14	10	23	8.5	27
D22611-10-12	G 3/4" x14	10	23	10	32
D22611-12-12	G 3/4" x14	12	23	10	32
D22611-16-16	G 1" x11	16	27.5	11	41
D22611-20-20	G 1.1/4" x11	20	31	11	50
D22611-24-24	G 1.1/2" x11	24	31	12	55
D22611-32-32	G 2" x11	32	36	14	70

NOTA

1. Para uso con mangueras trenzadas
2. Para uso con manguera espiralada la referencia cambia el ULTIMO digito

A = Alto corte conexión - C = Alto de la Cuerda - S2 = Diámetro Hexágono Cabeza

*NOTA: Para mangueras espiraladas la referencia en acoples, cambie el ultimo digito de 1 a 2.

*D22641

HEMBRA CODO 45° SELLO BSP ASIENTO (30°)

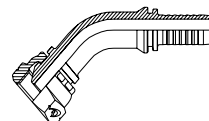

REFERENCIA	HILOS	DIAMETRO MANGUERA	DIMENSIONES			
		GUION	A	C	H	S2
D22641-04-04	G 1/4" x19	04	41	5.5	20	19
D22641-05-04	G 1/4" x19	05	41	5.5	20	19
D22641-06-04	G 1/4" x19	06	41.5	5.5	21.5	19
D22641-04-06	G 3/8" x19	04	42.5	6.5	22.5	22
D22641-05-06	G 3/8" x19	05	43	6.5	22.5	22
D22641-06-06	G 3/8" x19	06	50	6.5	23	22
D22641-08-08	G 1/2" x14	08	50	8	23	27
D22641-08-10	G 5/8" x14	08	51	8	24	27
D22641-10-10	G 5/8" x14	10	64	8.5	25	27
D22641-10-12	G 3/4" x14	10	64.4	10	25.4	32
D22641-12-12	G 3/4" x14	12	70	10	27	32
D22641-12-16	G 1" x11	12	71.5	11	28.5	41
D22641-16-16	G 1" x11	16	87	11	41	41
D22641-20-20	G 1.1/4" x11	20	105	11	47	50
D22641-24-24	G 1.1/2" x11	24	111	12	50	55
D22641-32-32	G 2" x11	32	181	14	61	70

NOTA

1. Para uso con mangueras trenzadas
2. Para uso con manguera espiralada la referencia cambia el ULTIMO digito

A = Alto corte conexión - C = Alto de la Cuerda - H = Longitud de Caída - S2 = Diámetro Hexágono Cabeza

*NOTA: Para mangueras espiraladas la referencia en acoples, cambie el ultimo digito de 1 a 2.

***D22691**

HEMBRA CODO 90° SELLO BSP ASIENTO (30°)

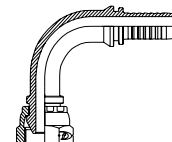

REFERENCIA	HILOS	DIAMETRO MANGUERA	DIMENSIONES			
		GUION	A	C	H	S2
D22691-03-02	G 1/8" x28	03	26	4	29	14
D22691-04-02	G 1/8" x28	04	28.5	4	32	14
D22691-04-04	G 1/4" x19	04	28.5	5.5	32	19
D22691-05-04	G 1/4" x19	05	30.5	5.5	35	19
D22691-06-04	G 1/4" x19	06	34	5.5	38.5	19
D22691-04-06	G 3/8" x19	04	28.5	6.5	33	22
D22691-05-06	G 3/8" x19	05	30.5	6.5	36	22
D22691-06-06	G 3/8" x19	06	34	6.5	39.5	22
D22691-06-08	G 1/2" x19	06	34	8	41	22
D22691-08-08	G 1/2" x14	08	42	8	47.5	27
D22691-08-10	G 5/8" x14	08	42	8.5	49	27
D22691-10-10	G 5/8" x14	10	51	8.5	55	27
D22691-10-12	G 3/4" x14	10	51	10	56	32
D22691-12-12	G 3/4" x14	12	57	10	61	32
D22691-16-16	G 1" x11	16	69	11	73	41
D22691-20-20	G 1.1/4" x11	20	83	11	87.5	50
D22691-24-24	G 1.1/2" x11	24	94	12	98	55
D22691-32-32	G 2" x11	32	122	14	127	70

NOTA

1. Para uso con mangueras trenzadas
2. Para uso con manguera espiralada la referencia cambia el ULTIMO digito

A = Alto corte conexión - C = Alto de la Cuerda - H = Longitud de Caída - S2 = Diámetro Hexágono Cabeza

*NOTA: Para mangueras espiraladas la referencia en acoples, cambie el ultimo digito de 1 a 2.

*D22611D

HEMBRA BSP RECTA ASIENTO (30°) DOBLE HEXAGONO

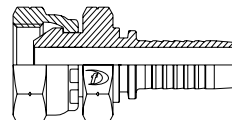

REFERENCIA	HILOS	DIAMETRO MANGUERA	DIMENSIONES			
		GUION	A	C	S1	S2
D22611D-04-04	G 1/4" x19	04	24	5.5	14	19
D22611D-06-06	G 3/8" x19	06	26.5	6.5	19	22
D22611D-08-08	G 1/2" x14	08	29	8	22	27
D22611D-10-10	G 5/8" x14	10	31.5	8.5	30	27
D22611D-12-12	G 3/4" x14	12	33	10	32	32
D22611D-16-16	G 1" x11	16	39	11	41	41
D22611D-20-20	G 1.1/4" x11	20	40	11	46	50

NOTA

1. Para uso con mangueras trenzadas
2. Para uso con manguera espiralada la referencia cambia el ULTIMO digito

A = Alto corte conexión - C = Alto de la Cuerda - S2 = Diámetro Hexágono Cabeza - S1 = Diámetro Hexágono

*D22691K

HEMBRA CODO 90° SELLO BSP ASIENTO (30°) DOBLE HEXAGONO

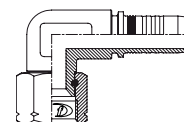

REFERENCIA	HILOS	DIAMETRO MANGUERA	DIMENSIONES				
		GUION	A	C	H	S1	S2
D22691K-04-04	G 1/4" x19	04	16.5	5.5	23	12	19
D22691K-06-06	G 3/8" x19	06	18.5	6.5	26	15	22
D22691K-08-08	G 1/2" x14	08	20.5	8	28.5	19	27
D22691K-10-10	G 5/8" x14	10	24	8.5	31	22	27
D22691K-12-12	G 3/4" x14	12	25.5	10	33	25	32
D22691K-16-16	G 1" x11	16	38	11	40	32	41

NOTA

1. Para uso con mangueras trenzadas
2. Para uso con manguera espiralada la referencia cambia el ULTIMO digito

A = Alto corte conexión - C = Alto de la Cuerda - H = Longitud de Caída - S1 = Diámetro Hexágono - S2 = Diámetro Hexágono Cabeza

*NOTA: Para mangueras espiraladas la referencia en acoples, cambie el ultimo digito de 1 a 2.

***D16011** ISO 11926 - SAE J1926
MACHO O-RING BOSS RECTO

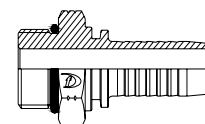

REFERENCIA	HILOS	DIAMETRO MANGUERA		O-RING	DIMENSIONES		
		DN	GUION		A	C	S1
D16011-04-04	7/16" x20	6	04	O904	21.5	9.1	14
D16011-04-05	1/2" x20	6	04	O905	21.5	9.1	17
D16011-05-06	9/16" x18	8	05	O906	22.5	9.9	17
D16011-06-06	9/16" x18	10	06	O906	22.5	9.9	17
D16011-06-08	3/4" x16	10	06	O908	27	11.1	22
D16011-08-08	3/4" x16	12	08	O908	27	11.1	22
D16011-08-10	7/8" x14	12	08	O910	29.5	12.7	27
D16011-10-10	7/8" x14	16	10	O910	30.5	12.7	27
D16011-10-12	1.1/16" x12	16	10	O912	34	15.1	32
D16011-12-12	1.1/16" x12	20	12	O912	34	15.1	32
D16011-16-16	1.5/16" x12	25	16	O916	35.5	15.1	38

NOTA

1. Para uso con mangueras trenzadas
2. Para uso con manguera espiralada la referencia cambia el ULTIMO digito

A = Alto corte conexión - C = Alto de la Cuerda - S1 = Diámetro Hexágono

*NOTA: Para mangueras espiraladas la referencia en acoples, cambie el ultimo digito de 1 a 2.

***D15611** SAE J 516
MACHO NPT RECTO ASIENTO 30°

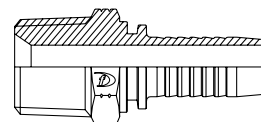

REFERENCIA	HILOS	DIAMETRO MANGUERA	DIMENSIONES		
		GUION	A	C	S1
D15611-03-02	Z 1/8" x27	03	23	10.5	12
D15611-04-04	Z 1/4" x18	04	27.5	14	14
D15611-05-06	Z 3/8" x18	05	31	16	19
D15611-06-06	Z 3/8" x18	06	31	16	19
D15611-08-06	Z 3/8" x18	08	32	16	22
D15611-06-08	Z 1/2" x14	06	35	19	22
D15611-08-08	Z 1/2" x14	08	35	19	22
D15611-10-08	Z 1/2" x14	10	36	19	22
D15611-08-12	Z 3/4" x14	08	36.5	19.5	27
D15611-10-12	Z 3/4" x14	10	37.5	19.5	27
D15611-12-12	Z 3/4" x14	12	37.5	19.5	27
D15611-12-16	Z 1" x11.5	12	45.5	25.5	36
D15611-16-16	Z 1" x11.5	16	46	26.5	36
D15611-16-20	Z 1.1/4" x11.5	16	48	26.5	46
D15611-20-20	Z 1.1/2" x11.5	20	48.5	26.5	46
D15611-24-24	Z 1.1/2" x11.5	24	49	25	50
D15611-32-32	Z 2" x11.5	32	53	27.5	65

NOTA

1. Para uso con mangueras trenzadas
2. Para uso con manguera espiralada la referencia cambia el ULTIMO digito

A = Alto corte conexión - C = Alto de la Cuerda - S1 = Diámetro Hexágono

***D16711** ISO 8434-2 - SAE J514
MACHO JIC RECTO CONO (37°)

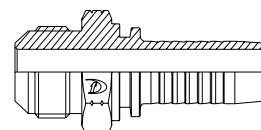

REFERENCIA	HILOS	DIAMETRO MANGUERA	DIMENSIONES		
		GUION	A	C	S1
D16711-03-04	7/16" x20	03	27.5	14	14
D16711-04-04	7/16" x20	04	27.5	14	14
D16711-05-05	1/2" x20	05	28	14	17
D16711-05-06	9/16" x18	05	28.5	14.5	17
D16711-06-06	9/16" x18	06	28.5	14.5	17
D16711-06-08	3/4" x16	06	33	14.5	22
D16711-08-08	3/4" x16	08	33	17	22
D16711-10-10	7/8" x14	10	36.5	19.5	24
D16711-08-12	1.1/16" x12	08	39	22	27
D16711-10-12	1.1/16" x12	10	40	22	27
D16711-12-12	1.1/16" x12	12	40	22	27
D16711-12-16	1.5/16" x12	12	43	23	36
D16711-16-16	1.5/16" x12	16	44.5	23	36
D16711-16-20	1.5/8" x12	16	47.5	25	46
D16711-20-20	1.5/8" x12	20	48	25	46
D16711-20-24	1.7/8" x12	20	51	27.5	50
D16711-24-24	1.7/8" x12	24	51	27.5	50
D16711-32-32	2.1/2" x12	32	61	35	65

NOTA

1. Para uso con mangueras trenzadas
2. Para uso con manguera espiralada la referencia cambia el ULTIMO digito

A = Alto corte conexión - **C** = Alto de la Cuerda - **S1** = Diámetro Hexágono

*NOTA: Para mangueras espiraladas la referencia en acoples, cambie el ultimo digito de 1 a 2.

***D26711** SAE J514
HEMBRA RECTA JIC ASIENTO (37°)

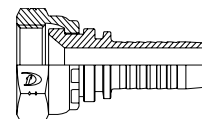

REFERENCIA	HILOS	DIAMETRO MANGUERA	DIMENSIONES		
		GUION	A	C	S1
D26711-03-04	7/16" x20	03	15.5	8.5	17
D26711-04-04	7/16" x20	04	15.5	8.5	17
D26711-05-05	1/2" x20	05	16	9.5	17
D26711-05-06	9/16" x18	05	17	9.5	19
D26711-06-06	9/16" x18	06	18	9.5	19
D26711-06-08	3/4" x16	06	19	9.5	24
D26711-08-08	3/4" x16	08	19	9.5	24
D26711-10-10	7/8" x14	10	20	12.5	27
D26711-10-12	1.1/16" x12	10	21	13.5	32
D26711-12-12	1.1/16" x12	12	21	13.5	32
D26711-16-12	1.1/16" x12	16	23	15	32
D26711-12-16	1.5/16" x12	12	23	15	41
D26711-16-16	1.5/16" x12	16	24.5	15	41
D26711-16-20	1.5/8" x12	16	25.5	15.5	50
D26711-20-20	1.5/8" x12	20	25.5	15.5	50
D26711-20-24	1.7/8" x12	20	26	17	55
D26711-24-24	1.7/8" x12	24	26	17	55
D26711-32-32	2.1/2" x12	32	29	23.5	75

NOTA

1. Para uso con mangueras trenzadas
2. Para uso con manguera espiralada la referencia cambia el ULTIMO digito

A = Alto corte conexión - **C** = Alto de la Cuerda - **S1** = Diámetro Hexágono

***D26741** SAE J514
HEMBRA CODO 45° SELLO JIC ASIENTO (37°)

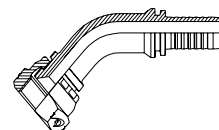

REFERENCIA	HILOS	DIAMETRO MANGUERA	DIMENSIONES			
		GUION	A	C	H	S2
D26741-03-04	7/16" x20	03	33	8.5	15	17
D26741-04-04	7/16" x20	04	34.5	8.5	16.5	17
D26741-04-05	1/2" x20	04	34.5	9.5	16.5	17
D26741-05-05	1/2" x20	05	34.5	9.5	16.5	17
D26741-04-06	9/16" x18	04	34.5	9.5	16.5	19
D26741-05-06	9/16" x18	05	35	9.5	17	19
D26741-06-06	9/16" x18	06	40	9.5	19	19
D26741-06-08	3/4" x16	06	41	9.5	20	24
D26741-08-08	3/4" x16	08	48	9.5	22	24
D26741-08-10	7/8" x14	08	48	12.5	22	27
D26741-10-10	7/8" x14	10	55	12.5	25.5	27
D26741-08-12	1.1/16" x12	08	49	13.5	23	32
D26741-10-12	1.1/16" x12	10	56	13.5	26.5	32
D26741-12-12	1.1/16" x12	12	61	13.5	28.5	32
D26741-16-12	1.1/16" x12	16	68.5	15	32	32
D26741-12-16	1.5/16" x12	12	62	15	29.5	41
D26741-16-16	1.5/16" x12	16	69.5	15	33	41
D26741-20-16	1.5/16" x12	20	82.5	15	38.5	50

NOTA

1. Para uso con mangueras trenzadas
2. Para uso con manguera espiralada la referencia cambia el ULTIMO digito

A = Alto corte conexión - **C** = Alto de la Cuerda - **H** = Longitud de Caída - **S2** = Diámetro Hexágono Cabeza

*NOTA: Para mangueras espiraladas la referencia en acoples, cambie el ultimo digito de 1 a 2.

*D26791 SAE J514

HEMBRA CODO 90° SELLO JIC ASIENTO (37°)

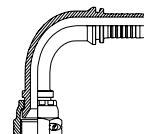

REFERENCIA	HILOS	DIAMETRO MANGUERA	DIMENSIONES			
		GUION	A	C	H	S2
D26791-03-04	7/16" x20	03	26	8.5	27	17
D26791-04-04	7/16" x20	04	28.5	8.5	30	17
D26791-05-05	1/2" x20	05	30.5	9.5	33	17
D26791-05-06	9/16" x18	05	30.5	9.5	33	19
D26791-06-06	9/16" x18	06	34	9.5	36.5	19
D26791-06-08	3/4" x16	06	34	9.5	38.5	24
D26791-08-08	3/4" x16	08	42	9.5	45	24
D26791-10-10	7/8" x14	10	51	12.5	51	27
D26791-10-12	1.1/16" x12	10	51	13.5	53	32
D26791-12-12	1.1/16" x12	12	57	13.5	58	32
D26791-16-12	1.1/16" x12	16	69	15	69	32
D26791-12-16	1.5/16" x12	12	57	15	59	41
D26791-16-16	1.5/16" x12	16	69	15	70	41
D26791-20-16	1.5/16" x12	20	83	15.5	82	50
D26791-20-20	1.5/8" x12	20	83	15.5	82	50
D26791-20-24	1.7/8" x12	20	83	17	83	55
D26791-24-24	1.7/8" x12	24	94	17	93	55
D26791-32-32	2.1/2" x12	32	122	23.5	115	75

NOTA

1. Para uso con mangueras trenzadas
2. Para uso con manguera espiralada la referencia cambia el ULTIMO digito

A = Alto corte conexión - C = Alto de la Cuerda - H = Longitud de Caída - S2 = Diámetro Hexágono Cabeza

DT36711 SAE J514
HEMBRA JIC ASIENTO (37°) (INTEGRAL)

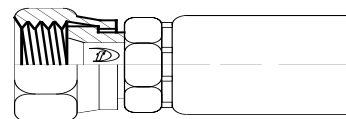

REFERENCIA	HILOS	DIAMETRO MANGUERA		DIMENSIONES			
		DN	GUION	A	C	S1	S2
DT36711-04-04	7/16" x20	6	04	15	9	14	14
DT36711-04-06	9/16" x18	6	04	15	10.5	14	14
DT36711-06-06	9/16" x18	10	06	15.5	10.5	19	19
DT36711-08-08	3/4" x16	12	08	18	11	24	24
DT36711-10-10	7/8" x14	16	10	20	13	27	27
DT36711-12-12	1.1/16" x12	20	12	21.5	15	32	32
DT36711-16-16	1.5/16" x12	25	12	23	16	41	41
DT36711-20-20	1.5/8" x12	32	20	26	17	50	50
DT36711-24-24	1.7/8" x12	40	24	26.5	20	55	55
DT36711-32-32	2.1/2" x12	50	32	27	23.5	75	75

NOTA

1. Para uso con mangueras trenzadas
2. Para uso con manguera espiralada la referencia cambia el ULTIMO digito

A = Alto corte conexión - C = Alto de la Cuerda - S1 = Diámetro Hexágono - S2 = Diámetro Hexágono Cabeza

DT36791 SAE J514

HEMBRA CODO 90° SELLO JIC ASIENTO (37°) INTEGRAL

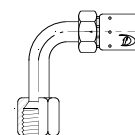

REFERENCIA	HILOS	DIAMETRO MANGUERA		DIMENSIONES			
		DN	GUION	C	H	S1	S2
DT36791-04-04	7/16" x20	6	04	9	27	15	15
DT36791-06-06	9/16" x18	10	06	10.5	34.5	19	19
DT36791-08-08	3/4" x16	12	08	11	42	24	24
DT36791-10-10	7/8" x14	16	10	13	49	27	27
DT36791-12-12	1.1 /16x12	20	12	15	54	32	32
DT36791-16-16	1.5/16" x12	25	16	16	68	41	41
DT36791-20-20	1.5/8" x12	32	20	17	80	50	50
DT36791-24-24	1.7/8" x12	40	24	20	91	55	55
DT36791-32-32	2.1/2" x12	50	32	23.5	115	75	75

NOTA

1. Para uso con mangueras trenzadas
2. Para uso con manguera espiralada la referencia cambia el ULTIMO digito

C = Alto de la Cuerda - H = Longitud de caída - S1 = Diámetro Hexágono - S2 = Diámetro Hexágono Cabeza

*D26711D SAE J514

HEMBRA JIC ASIENTO (37°) DOBLE HEXAGONO

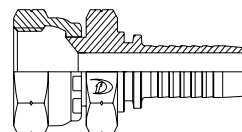

REFERENCIA	HILOS	DIAMETRO MANGUERA	DIMENSIONES			
		GUION	A	C	S1	S2
D26711D-04-04	7/16" x20	04	21.5	8.5	14	17
D26711D-04-06	9/16" x18	04	22.5	9.5	17	19
D26711D-06-06	9/16" x18	06	23	9.5	17	19
D26711D-06-08	3/4" x16	06	25	9.5	22	24
D26711D-08-08	3/4" x16	08	25	9.5	22	24
D26711D-10-08	3/4" x16	10	26	9.5	22	24
D26711D-08-10	7/8" x14	08	27	12.5	24	27
D26711D-10-10	7/8" x14	10	28	12.5	24	27
D26711D-12-12	1.1/16" x12	12	31	13.5	32	32
D26711D-12-16	1.5/16" x12	12	33.5	15	41	41
D26711D-16-16	1.5/16" x12	16	35	15	41	41
D26711D-20-16	1.5/16" x12	20	35.5	15	41	41
D26711D-20-20	1.7/16" x14	20	36.5	15.5	46	50

NOTA

1. Para uso con mangueras trenzadas
2. Para uso con manguera espiralada la referencia cambia el ULTIMO digito

A = Alto corte conexión - C = Alto de la Cuerda - S1 = Diámetro Hexágono - S2 = Diámetro Hexágono Cabeza

***D26791K** SAE J514

HEMBRA CODO 90° SELLO JIC (37°) COMPACTA

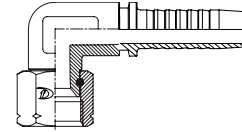

REFERENCIA	HILOS	DIAMETRO MANGUERA		DIMENSIONES				
		DN	GUION	A	C	H	S1	S2
D26791K-04-04	7/16" x20	6	04	17.5	9	18	11	15
D26791K-04-06	9/16" x18	6	04	19	10.5	21	14	19
D26791K-06-06	9/16" x18	10	06	20	10.5	21	16	19
D26791K-06-08	3/4" x16	10	06	23	11	25	19	24
D26791K-08-08	3/4" x16	12	08	23.5	11	25	22	24
D26791K-08-10	7/8" x14	12	08	23.5	13	27.5	22	27
D26791K-10-10	7/8" x14	16	10	25	13	27.5	22	27
D26791K-12-12	1.1/16" x12	20	12	27.5	15	30	27	32
D26791K-16-16	1.5/16" x12	25	16	43	16	34.3	33	41

NOTA

1. Para uso con mangueras trenzadas
2. Para uso con manguera espiralada la referencia cambia el ULTIMO digito

A = Alto corte conexión - C = Alto de la Cuerda - H = Longitud de Caída - S1 = Diámetro Hexágono - S2 = Diámetro Hexágono Cabeza

***D17811** SAE J513
MACHO SAE ASIENTO (45°)

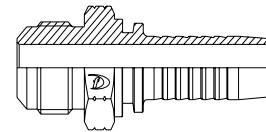

REFERENCIA	HILOS	DIAMETRO MANGUERA		DIMENSIONES		
		DN	GUION	C	H	S2
D17811-04-04	7/16" x20	6	04	25.5	12.7	12
D17811-05-05	1/2" x20	8	05	27	14.2	14
D17811-06-06	5/8" x18	10	06	28.5	15.7	17
D17811-08-08	3/4" x16	12	08	34	19	22
D17811-10-10	7/8" x14	16	10	38.5	22.4	24
D17811-12-12	1.1/16" x14	20	12	43.5	25.4	30

NOTA

1. Para uso con mangueras trenzadas
2. Para uso con manguera espiralada la referencia cambia el ULTIMO digito

C = Alto de la Cuerda - H = Longitud de Caída - S2 = Diámetro Hexágono Cabeza

*NOTA: Para mangueras espiraladas la referencia en acoples, cambie el ultimo digito de 1 a 2.

***D27811** SAE J513
HEMBRA RECTA SAE ASIENTO (45°)

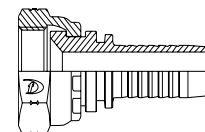

REFERENCIA	HILOS	DIAMETRO MANGUERA		DIMENSIONES		
		DN	GUION	A	C	S1
D27811-04-04	7/16" x20	6	04	15	9	15
D27811-05-05	1/2" x20	8	05	15.5	9.5	17
D27811-05-06	5/8" x18	8	05	17	11.3	22
D27811-06-06	5/8" x18	10	06	17	11.3	22
D27811-08-08	3/4" x16	12	08	19	9.5	24
D27811-10-10	7/8" x14	16	10	20	13	27
D27811-12-12	1.1/16" x14	20	12	21.5	14.3	32

NOTA

1. Para uso con mangueras trenzadas
2. Para uso con manguera espiralada la referencia cambia el ULTIMO digito

A = Alto corte conexión - C = Alto de la Cuerda - S1 = Diámetro Hexágono

***D27841** SAE J513
HEMBRA CODO 45° SAE ASIENTO (45°)

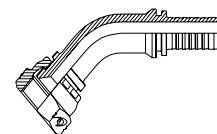

REFERENCIA	HILOS	DIAMETRO MANGUERA		DIMENSIONES			
		DN	GUION	A	C	H	S2
D27841-05-06	5/8" x18	8	05	33.5	11.3	15.5	22
D27841-06-06	5/8" x18	10	06	38	11.3	17	22
D27841-08-08	3/4" x16	12	08	45.5	11	20.5	24
D27841-08-10	7/8" x14	12	08	46	13	21	27
D27841-10-10	7/8" x14	16	10	51.5	13	23.5	27
D27841-12-12	1.1/16" x14	20	12	59	14.3	26	32

NOTA

1. Para uso con mangueras trenzadas
2. Para uso con manguera espiralada la referencia cambia el ULTIMO digito

A = Alto corte conexión - C = Alto de la Cuerda - H = Longitud de Caída - S2 = Diámetro Hexágono Cabeza

*NOTA: Para mangueras espiraladas la referencia en acoples, cambie el ultimo digito de 1 a 2.

***D27891** SAE J513
HEMBRA CODO 90° SAE ASIENTO (45°)

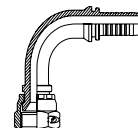

REFERENCIA	HILOS	DIAMETRO MANGUERA		DIMENSIONES			
		DN	GUION	A	C	H	S2
D27891-03-04	7/16" x20	5	03	26	9	25	15
D27891-04-06	5/8" x18	6	04	28.5	11.3	29	22
D27891-05-06	5/8" x18	8	05	30.5	11.3	32	22
D27891-06-06	5/8" x18	10	06	34	11.3	35	22
D27891-08-10	7/8" x14	12	08	42	13	42	27
D27891-10-10	7/8" x14	16	10	51	13	48	27
D27891-12-12	1.1/16" x14	20	12	57	14.3	54	32

NOTA

1. Para uso con mangueras trenzadas
2. Para uso con manguera espiralada la referencia cambia el ULTIMO digito

A = Alto corte conexión - C = Alto de la Cuerda - H = Longitud de Caída - S2 = Diámetro Hexágono Cabeza

***D14211** ISO 8434-3 - SAE J1453
MACHO ORFS

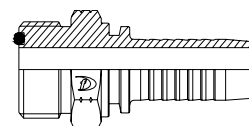

REFERENCIA	HILOS	DIAMETRO MANGUERA		O-RING	DIMENSIONES		
		GUION	A		C	S1	
D14211-04-04	9/16" x18	04	0011	24.5	11	17	
D14211-06-06	11/16" x16	06	0012	28	13	19	
D14211-08-08	13/16" x16	08	0014	30	14	22	
D14211-08-10	1" x14	08	0016	34	17	27	
D14211-10-10	1" x14	10	0016	35	17	27	
D14211-10-12	1.3/16" x12	10	0018	38	19	31	
D14211-12-12	1.3/16" x12	12	0018	38	19	32	
D14211-12-16	1.7/16" x12	12	0021	37	19	38	
D14211-16-16	1.7/16" x12	16	0021	39.5	19	38	

NOTA

1. Para uso con mangueras trenzadas
2. Para uso con manguera espiralada la referencia cambia el ULTIMO digito

A = Alto corte conexión - C = Alto de la Cuerda - S1 = Diámetro Hexágono

*NOTA: Para mangueras espiraladas la referencia en acoples, cambie el ultimo digito de 1 a 2.

***D24211 - D24211T** ISO 12151 - 1-SAE J516
HEMBRA RECTA SELLO ORFS

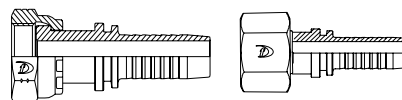

REFERENCIA	HILOS	DIAMETRO MANGUERA	DIMENSIONES		
		GUION	A	C	S2
D24211-04-04	9/16" x18	04	23.5	8.5	19
D24211-05-04	9/16" x18	05	24	9.5	19
D24211-04-06	11/16" x18	04	25.5	9.5	19
D24211-05-06	11/16" x18	05	26	9.5	22
D24211-06-06	11/16" x18	06	26	9.5	22
D24211-06-08	13/16" x16	06	29.5	11	27
D24211-08-08	13/16" x16	08	29.5	11	27
D24211-10-08	13/16" x16	10	30.5	11	27
D24211-08-10	1" x14	08	30	12	32
D24211-10-10	1" x14	10	31	12	32
D24211-12-10	1" x14	12	31	12	32
D24211T-08-12	1.3/16" x12	08	30	14	36
D24211T-10-12	1.3/16" x12	10	31	14	36
D24211T-12-12	1.3/16" x12	12	31	14	36
D24211T-12-16	1.7/16" x12	12	32	14	41
D24211T-16-16	1.7/16" x12	16	33.5	14	41
D24211T-16-20	1.11/16" x12	16	35.5	15	50
D24211T-20-20	1.11/16" x12	20	36	15	50

NOTA

1. Para uso con mangueras trenzadas
2. Para uso con manguera espiralada la referencia cambia el ULTIMO digito

A = Alto corte conexión - C = Alto de la Cuerda - S2 = Diámetro Hexágono Cabeza

*NOTA: Para mangueras espiraladas la referencia en acoples, cambie el ultimo digito de 1 a 2.

***D24241 - D24241T** ISO 12151 - 1-SAE J516
HEMBRA CODO 45° SELLO ORFS

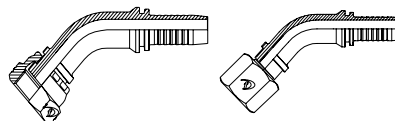

REFERENCIA	HILOS	DIAMETRO MANGUERA	DIMENSIONES			
		GUION	A	C	H	S2
D24241-04-04	9/16" x18	04	33	8.5	15	19
D24241-05-04	9/16" x18	05	33	9.5	15.5	19
D24241-04-06	11/16" x18	04	33	9.5	15	19
D24241-05-06	11/16" x18	05	33	9.5	15.5	22
D24241-06-06	11/16" x18	06	33	9.5	15.5	22
D24241-06-08	13/16" x16	06	38.5	11	17.5	27
D24241-08-08	13/16" x16	08	45.5	11	20.5	27
D24241-10-08	13/16" x16	10	51	11	23	27
D24241-08-10	1" x14	08	50.5	12	22.5	32
D24241-10-10	1" x14	10	48	12	21	32
D24241-12-10	1" x14	12	54.5	12	25.5	32
D24241T-08-12	1.3/16" x12	08	51	14	23	36
D24241T-10-12	1.3/16" x12	10	56.5	14	25.5	36
D24241T-12-12	1.3/16" x12	12	60	14	27.5	36
D24241T-12-16	1.7/16" x12	12	62	14	29.5	41
D24241T-16-16	1.7/16" x12	16	69.5	14	33	41
D24241T-16-20	1.11/16" x12	16	69.5	15	33	50
D24241T-20-20	1.11/16" x12	20	82.5	15	38.5	50

NOTA

1. Para uso con mangueras trenzadas
2. Para uso con manguera espiralada la referencia cambia el ULTIMO digito

A = Alto corte conexión - C = Alto de la Cuerda - H = Longitud de Caída - S2 = Diámetro Hexágono Cabeza

*NOTA: Para mangueras espiraladas la referencia en acoples, cambie el ultimo digito de 1 a 2.

***D24291 - D24291T** ISO 12151 - 1-SAE J516

HEMBRA CODO 90° SELLO ORFS

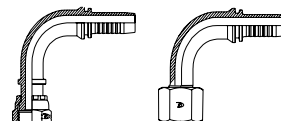

REFERENCIA	HILOS	DIAMETRO MANGUERA	DIMENSIONES			
		GUION	A	C	H	S2
D24291-04-04	9/16" x18	04	28.5	8.5	28	19
D24291-05-04	9/16" x18	05	30.5	9.5	31	19
D24291-05-06	11/16" x18	05	30.5	9.5	31	19
D24291-06-06	11/16" x18	06	34	9.5	34.5	22
D24291-08-06	11/16" x18	08	42	9.5	34.5	22
D24291-06-08	13/16" x16	06	34	11	35.5	27
D24291-08-08	13/16" x16	08	42	11	42	27
D24291-10-08	13/16" x16	10	51	11	48	27
D24291-08-10	1" x14	08	42	12	43	32
D24291-10-10	1" x14	10	51	12	49	32
D24291-12-10	1" x14	12	57	12	54	32
D24291T-08-12	1.3/16" x12	08	42	14	45	36
D24291T-10-12	1.3/16" x12	10	51	14	49	36
D24291T-12-12	1.3/16" x12	12	57	14	56	36
D24291T-12-16	1.7/16" x12	12	57	14	59	41
D24291T-16-16	1.7/16" x12	16	69	14	70	41
D24291T-16-20	1.11/16" x12	16	69	15	70	50
D24291T-20-20	1.11/16" x12	20	83	15	82	50

NOTA

1. Para uso con mangueras trenzadas
2. Para uso con manguera espiralada la referencia cambia el ULTIMO digito

A = Alto corte conexión - **C** = Alto de la Cuerda - **H** = Longitud de Caída - **S2** = Diámetro Hexágono Cabeza

*NOTA: Para mangueras espiraladas la referencia en acoples, cambie el ultimo digito de 1 a 2.

***D21611** SAE J514
HEMBRA NPSM ASIENTO A 30°

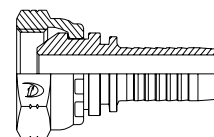

REFERENCIA	HILOS	DIAMETRO MANGUERA		DIMENSIONES		
		DN	GUION	A	C	S2
D21611-04-04	1/4" x18	6	04	22	4.6	19
D21611-06-06	3/8" x18	10	06	23	6	22
D21611-08-08	1/2" x14	12	08	23.5	7.5	27
D21611-12-12	3/4" x14	20	12	27	8.9	32
D21611-16-16	1" x11.5	25	16	28.5	10.5	41
D21611-20-20	1.1/4" x11.5	32	20	29.5	11.2	50
D21611-20-24	1.1/2" x11.5	32	20	29.5	11.2	55
D21611-24-24	1.1/2" x11.5	40	24	31.5	11.2	55
D21611-32-32	2" x11.5	50	32	31	11.2	70

NOTA

1. Para uso con mangueras trenzadas
2. Para uso con manguera espiralada la referencia cambia el ULTIMO digito

A = Alto corte conexión - C = Alto de la Cuerda - S2 = Diámetro Hexágono Cabeza

***D21641** SAE J514
HEMBRA CODO 45° NPSM ASIENTO 30°

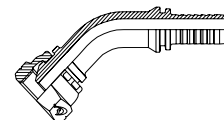

REFERENCIA	HILOS	DIAMETRO MANGUERA		DIMENSIONES			
		DN	GUION	A	C	H	S2
D21641-04-04	1/4" x18	6	04	45.1	4.6	23	19
D21641-06-06	3/8" x18	10	06	47.2	6	24.9	22
D21641-08-08	1/2" x14	12	08	62.7	7.5	27.7	27
D21641-12-12	3/4" x14	20	12	81.4	8.9	34	32
D21641-16-16	1" x11.5	25	16	89.2	10.5	35	41
D21641-20-20	1.1/4" x11.5	32	20	99.8	11.2	39.3	50
D21641-24-24	1.1/2" x11.5	40	24	115.1	11.2	44.4	55
D21641-32-32	2" x11.5	50	32	136.4	11.2	63.4	70

NOTA

1. Para uso con mangueras trenzadas
2. Para uso con manguera espiralada la referencia cambia el ULTIMO digito

A = Alto corte conexión - C = Alto de la Cuerda - H = Longitud de Caída - S2 = Diámetro Hexágono Cabeza

*NOTA: Para mangueras espiraladas la referencia en acoples, cambie el ultimo digito de 1 a 2.

***D21691** SAE J513
HEMBRA CODO 90° NPSM ASIENTO 30°

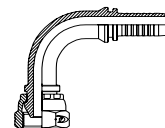

REFERENCIA	HILOS	DIAMETRO MANGUERA		DIMENSIONES			
		DN	GUION	A	B	H	S2
D21691-04-04	1/4" x18	6	04	28.5	4.6	40.5	19
D21691-06-06	3/8" x18	10	06	34	6	45.3	22
D21691-08-08	1/2" x14	12	08	42	7.5	53.2	27
D21691-12-12	3/4" x14	20	12	57	8.9	69.1	32
D21691-16-16	1" x11.5	25	16	69	10.5	75	41
D21691-20-20	1.1/4" x11.5	32	20	83	11.2	86	50
D21691-20-24	1.1/2" x11.5	32	20	83	11.2	83.5	55
D21691-24-24	1.1/2" x11.5	40	24	94	11.2	101.5	55
D21691-32-32	2" x11.5	50	32	122	11.2	124.5	70

NOTA

1. Para uso con mangueras trenzadas
2. Para uso con manguera espiralada la referencia cambia el ULTIMO digito

A = Alto corte conexión - B = Alto de la Cuerda - H = Longitud de Caída - S2 = Diámetro Hexágono Cabeza

DFL ISO 6162 - SAE J518
SEMIBRIDA SAE 3000 PSI CODIGO 61

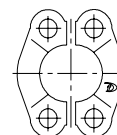

REFERENCIA	DIAMETRO NOMINAL FLANCHE	DIMENSIONES					TORNILLO	Mps
		A1	B	C2	E	T		
DFL-08	1/2"	53.8	46	38.1	17.5	9	M8 x25	34.5
DFL-12	3/4"	65	52.4	47.6	22.2	11	M10 x30	
DFL-16	1"	70	58.7	52.4	26.2	11	M10 x30	
DFL-20	1.1/4"	79	73	58.7	30.2	11	M10 x30	27.6
DFL-24	1.1/2"	94	82.6	69.9	35.7	13.5	M12 x35	20.7
DFL-32	2"	102	96.8	77.8	42.9	13.5	M12 x35	
DFL-40	2.1/4"	114	109	88.9	50.8	13.5	M12 x40	

NOTA

Los tornillos no son incluidos

A1 = Largo total semi-brida - B = Ancho semi-brida - C2 = Centro entre Pernos "A" - E = Centro entre Pernos "B" - T = Diámetro para Perno

*NOTA: Para mangueras espiraladas la referencia en acoples, cambie el ultimo digito de 1 a 2.

***D87311** ISO 12151-3 - SAE J516
 FLANCHE RECTO SAE 3000 PSI CODIGO 61

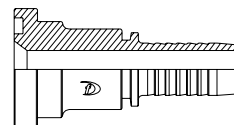

REFERENCIA	DIAMETRO NOMINAL FLANCHE	DIAMETRO MANGUERA	DIMENSIONES			
		GUION	A	C1	D1	L1
D87311-08-08	1/2"	08	46	30.2	24	6.8
D87311-08-12	3/4"	08				
D87311-10-12	3/4"	10	48	38.1	31.5	6.8
D87311-12-12	3/4"	12	48	38.1	31.5	6.8
D87311-16-12	3/4"	16	49.5	38.1	31.5	6.8
D87311-12-16	1"	12	50.5	44.4	38	8
D87311-16-16	1"	16	52	44.4	38	8
D87311-20-16	1"	20	52.5	44.4	38	8
D87311-16-20	1.1/4"	16	57.5	50.8	42	8
D87311-20-20	1.1/4"	20	58	50.8	42	8
D87311-20-24	1.1/2"	20	68	60.3	50	8
D87311-24-24	1.1/2"	24	68	60.3	50	8
D87311-24-32	2"	24	70	71.4	61.5	9.6
D87311-32-32	2"	32	70	71.4	61.5	9.6
D87311-40-40	2.1/2"	40	76	84.1	74	9.6

NOTA

1. Para uso con mangueras trenzadas
2. Para uso con manguera espiralada la referencia cambia el ULTIMO digito

A = Alto corte conexión - **C1 =** Diámetro Brida - **D1 =** Diámetro Cuello - **L1 =** Alto cabeza

*NOTA: Para mangueras espiraladas la referencia en acoples, cambie el ultimo digito de 1 a 2.

***D87341** ISO 12151-3 - SAE J516

FLANCHE CODO 45° SAE 3000 PSI CODIGO 61

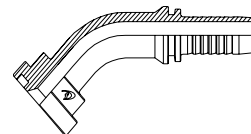

REFERENCIA	DIAMETRO NOMINAL FLANCHE	DIAMETRO MANGUERA GUION	DIMENSIONES				
			A	C	D	H	L
D87341-08-08	1/2"	08	48.5	30.2	24	23.5	6.8
D87341-08-12	3/4"	08	48.5	38.1	31.5	23.5	6.8
D87341-10-12	3/4"	10	60.5	38.1	31.5	26	6.8
D87341-12-12	3/4"	12	65.5	38.1	31.5	28	6.8
D87341-12-16	1"	12	62.5	44.4	38	30	8
D87341-16-16	1"	16	70	44.4	38	33.5	8
D87341-20-16	1"	20	83	44.4	38	39	8
D87341-16-20	1.1/4"	16	70	50.8	42	33.5	8
D87341-20-20	1.1/4"	20	83	50.8	42	39	8
D87341-20-24	1.1/2"	20	83	60.3	50	39	8
D87341-24-24	1.1/2"	24	85.5	60.3	50	42.5	8
D87341-24-32	2"	24	87.5	71.4	61.5	44	9.6
D87341-32-32	2"	32	115.5	71.4	61.5	54	9.6

NOTA

1. Para uso con mangueras trenzadas
2. Para uso con manguera espiralada la referencia cambia el ULTIMO digito

A = Alto corte conexión - **C1** = Diámetro Brida - **D1** = Diámetro Cuello - **H** = Longitud de Caída - **L1** = Alto cabeza

*NOTA: Para mangueras espiraladas la referencia en acoples, cambie el ultimo digito de 1 a 2.

***D87391** ISO 12151-3--SAE J516

FLANCHE CODO 90° SAE 3000 PSI CODIGO 61

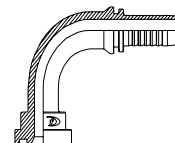

REFERENCIA	DIAMETRO NOMINAL FLANCHE	DIAMETRO MANGUERA	DIMENSIONES				
		GUION	A	C	D	H	L
D87391-08-08	1/2"	08	42	30.2	24	46	6.8
D87391-08-12	3/4"	08	42	38.1	31.5	46	6.8
D87391-10-12	3/4"	10	51	38.1	31.5	52	6.8
D87391-12-12	3/4"	12	57	38.1	31.5	57	6.8
D87391-16-12	3/4"	16	69	38.1	31.5	68	6.8
D87391-12-16	1"	12	57	44.4	38	60	8
D87391-16-16	1"	16	69	44.4	38	71	8
D87391-20-16	1"	20	83	44.4	38	83	8
D87391-16-20	1.1/4"	16	69	50.8	42	71	8
D87391-20-20	1.1/4"	20	83	50.8	42	83	8
D87391-20-24	1.1/2"	20	83	60.3	50	83	8
D87391-24-24	1.1/2"	24	94	60.3	50	93	8
D87391-24-32	2"	24	94	71.4	61.5	95	9.6
D87391-32-32	2"	32	122	71.4	61.5	119	9.6
D87391-40-40	2.1/2"	40	122	84.1	74	119	9.6

NOTA

1. Para uso con mangueras trenzadas
2. Para uso con manguera espiralada la referencia cambia el ULTIMO digito

A = Alto corte conexión - C1 = Diámetro Brida - D1 = Diámetro Cuello - H = Longitud de Caída - L1 = Alto cabeza

*NOTA: Para mangueras espiraladas la referencia en acoples, cambie el ultimo digito de 1 a 2.

***D87391H** ISO 12151-3 - SAE J516

FLANCHE CODO 90° XL SAE 3000 PSI CODIGO 61

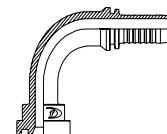

REFERENCIA	DIAMETRO NOMINAL FLANCHE	DIAMETRO MANGUERA	DIMENSIONES				
		GUION	A	C	D	H	L
D87391-12-12 (H90)	3/4"	12	57	38.1	31.5	90	6.8
D87391-12-12 (H100)	3/4"	12	57	38.1	31.5	100	6.8
D87391-12-12 (H127)	3/4"	12	57	38.1	31.5	127	6.8
D87391-12-12 (H150)	3/4"	12	57	38.1	31.5	150	6.8
D87391-16-16 (H100)	1"	16	69	44.4	38	100	8
D87391-16-16 (H127)	1"	16	69	44.4	38	127	8
D87391-16-16 (H150)	1"	16	69	44.4	38	150	8
D87391-20-20 (H100)	1.1/4"	20	83	50.8	42	100	8
D87391-20-20 (H127)	1.1/4"	20	83	50.8	42	127	8
D87391-20-20 (H150)	1.1/4"	20	83	50.8	42	150	8
D87391-24-24 (H127)	1.1/2"	24	94	60.3	50	127	8

NOTA

1. Para uso con mangueras trenzadas
2. Para uso con manguera espiralada la referencia cambia el ULTIMO digito

A = Alto corte conexión - C1 = Diámetro Brida - D1 = Diámetro Cuello - H = Longitud de Caída - L1 = Alto cabeza

*NOTA: Para mangueras espiraladas la referencia en acoples, cambie el ultimo digito de 1 a 2.

DFS ISO 6162 - SAE J518
SEMIBRIDA SAE 6000 PSI CODIGO 62

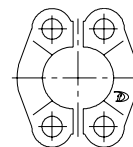

REFERENCIA	DIAMETRO NOMINAL FLANCHE	DIMENSIONES					TORNILLO	Mps
		A	B	C	E	T		
DFS-08	1/2"	56.3	49.2	40.5	18.2	9	M8 x30	42
DFS-12	3/4"	71.4	61.8	50.8	23.8	11	M10 x35	
DFS-16	1"	81	71.4	57.2	27.8	11	M12 x45	
DFS-20	1.1/4"	95.3	79.2	66.7	31.8	11	M14 x50	
DFS-24	1.1/2"	112.8	96.8	79.4	36.6	13.5	M16 x55	
DFS-32	2"	133.4	115.6	96.8	44.4	13.5	M20 x70	

NOTA

Los tornillos no son incluidos

A1 = Largo total semi-brida - **B** = Ancho semi-brida - **C2** = Centro entre Pernos "A" - **E** = Centro entre Pernos "B" - **T** = Diámetro para Perno

***D87611** ISO 12151-3 - SAE J516
FLANCHE RECTO SAE 6000 PSI CODIGO 62

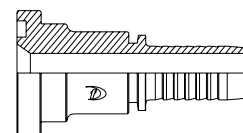

REFERENCIA	DIAMETRO NOMINAL FLANCHE	DIAMETRO MANGUERA GUION	DIMENSIONES			
			A	C1	D1	L
D87611-08-08	1/2"	08	47	31.7	24	7.8
D87611-10-12	3/4"	10	51	41.3	32	8.8
D87611-12-12	3/4"	12	51	41.3	32	8.8
D87611-12-16	1"	12	55.5	47.6	38	9.6
D87611-16-16	1"	16	57	47.6	38	9.6
D87611-20-16	1"	20	57.5	47.6	38	9.6
D87611-16-20	1.1/4"	16	65.5	54	44	10.4
D87611-20-20	1.1/4"	20	66	54	44	10.4
D87611-20-24	1.1/2"	20	75	63.5	51	12.7
D87611-24-24	1.1/2"	24	75	63.5	51	12.7
D87611-24-32	2"	24	84	79.4	67	12.7
D87611-32-32	2"	32	85	79.4	67	12.7

NOTA

1. Para uso con mangueras trenzadas
2. Para uso con manguera espiralada la referencia cambia el ULTIMO digito

A = Alto corte conexión - **C1** = Diámetro Brida - **D1** = Diámetro Cuello - **L1** = Alto cabeza

*NOTA: Para mangueras espiraladas la referencia en acoples, cambie el ultimo digito de 1 a 2.

*D87641 ISO 12151-3 - SAE J516

FLANCHE CODO 45° SAE 6000 PSI CODIGO 62

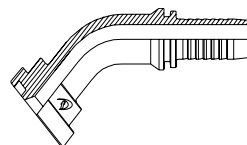

REFERENCIA	DIAMETRO NOMINAL FLANCHE	DIAMETRO MANGUERA	DIMENSIONES				
		GUION	A	C1	D1	H	L1
D87641-08-08	1/2"	08	49	31.7	24	24	7.8
D87641-12-12	3/4"	12	62	41.3	32	29.5	8.8
D87641-16-16	1"	16	71.5	47.6	38	35	9.6
D87641-20-20	1.1/4"	20	85	54	44	41	10.4
D87641-20-24	1.1/2"	20	88	63.5	51	44	12.7
D87641-24-24	1.1/2"	24	91	63.5	51	47.5	12.7
D87641-24-32	2"	24	91	79.4	67	47.5	12.7
D87641-32-32	2"	32	119	79.4	67	57.5	12.7

NOTA

1. Para uso con mangueras trenzadas
2. Para uso con manguera espiralada la referencia cambia el ULTIMO digito

A = Alto corte conexión - C1 = Diámetro Brida - D1 = Diámetro Cuello - H = Longitud de Caída - L1 = Alto cabeza

*D87691 ISO 12151-3 - SAE J516

FLANCHE CODO 90° SAE 6000 PSI CODIGO 62

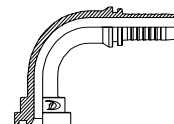

REFERENCIA	DIAMETRO NOMINAL FLANCHE	DIAMETRO MANGUERA	DIMENSIONES				
		GUION	A	C1	D1	H	L1
D87691-08-08	1/2"	08	42	31.7	24	47	7.8
D87691-10-12	3/4"	10	51	41.3	32	54	8.8
D87691-12-12	3/4"	12	57	41.3	32	59	8.8
D87691-12-16	1"	12	57	47.6	38	62	9.6
D87691-16-16	1"	16	69	47.6	38	73	9.6
D87691-20-16	1"	20	83	47.6	38	85	9.6
D87691-16-20	1.1/4"	16	69	54	44	73.5	10.4
D87691-20-20	1.1/4"	20	83	54	44	85.5	10.4
D87691-20-24	1.1/2"	20	83	63.5	44	90	12.7
D87691-24-24	1.1/2"	24	94	63.5	51	100	12.7
D87691-24-32	2"	24	94	79.4	67	100	12.7
D87691-32-32	2"	32	122	79.4	67	124	12.7

NOTA

1. Para uso con mangueras trenzadas
2. Para uso con manguera espiralada la referencia cambia el ULTIMO digito

A = Alto corte conexión - C1 = Diámetro Brida - D1 = Diámetro Cuello - H = Longitud de Caída - L1 = Alto cabeza

*NOTA: Para mangueras espiraladas la referencia en acoples, cambie el ultimo digito de 1 a 2.

D87613 ISO 12151-3 - SAE J516

FLANCHE RECTO SAE 6000 PSI CODIGO 62 PARA MANGUERA R13

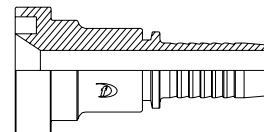

REFERENCIA	DIAMETRO NOMINAL FLANCHE	DIAMETRO MANGUERA	DIMENSIONES			
		GUION	A	C1	D1	L1
D87613-12-12	3/4"	12	48	38.1	31.5	8.8
D87613-16-12	3/4"	16	49.5	38.1	31.5	8.8
D87613-12-16	1"	12	50.5	44.4	38	9.6
D87613-16-16	1"	16	52	44.4	38	9.6
D87613-20-16	1"	20	52.5	44.4	38	9.6
D87613-16-20	1.1/4"	16	57.5	50.8	42	10.4
D87613-20-20	1.1/4"	20	58	50.8	42	10.4
D87613-20-24	1.1/2"	20	68	60.3	50	12.7
D87613-24-24	1.1/2"	24	68	60.3	50	12.7
D87613-24-32	2"	24	70	71.4	61.5	12.7
D87613-32-32	2"	32	70	71.4	61.5	12.7

NOTA

1. Para uso con mangueras trenzadas
2. Para uso con manguera espiralada la referencia cambia el ULTIMO digito

A = Alto corte conexión - C1 = Diámetro Brida - D1 = Diámetro Cuello - L1 = Alto cabeza

D87693 ISO 12151-3 - SAE J516

FLANCHE CODO 90° SAE 6000 PSI CODIGO 62 PARA MANGUERA R13

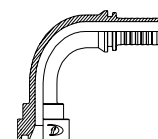

REFERENCIA	DIAMETRO NOMINAL FLANCHE	DIAMETRO MANGUERA	DIMENSIONES				
		GUION	A	C1	D1	H	L1
D87693-12-12	3/4"	12	57	41.3	32	59	8.8
D87693-12-16	1"	12	57	47.6	38	62	9.6
D87693-16-16	1"	16	69	47.6	38	73	9.6
D87693-20-16	1"	20	83	47.6	38	85	9.6
D87693-16-20	1.1/4"	16	69	54	44	73.5	10.4
D87693-20-20	1.1/4"	20	83	54	44	85.5	10.4
D87693-20-24	1.1/2"	20	83	63.5	44	90	12.7
D87693-24-24	1.1/2"	24	94	63.5	51	100	12.7
D87693-24-32	2"	24	94	79.4	67	100	12.7
D87693-32-32	2"	32	122	79.4	67	124	12.7

NOTA

1. Para uso con mangueras trenzadas
2. Para uso con manguera espiralada la referencia cambia el ULTIMO digito

A = Alto corte conexión - C1 = Diámetro Brida - D1 = Diámetro Cuello - H = Longitud de Caída - L1 = Alto cabeza

D87912 ISO 12151-3 - SAE J 516

FLANCHE RECTO SAE 9000 PSI SUPER CAT PARA MANGUERA R13

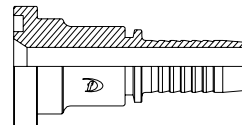

REFERENCIA	DIAMETRO NOMINAL FLANCHE	DIAMETRO MANGUERA	DIMENSIONES			
		GUION	A	C1	D1	L1
D87912-12-12	3/4"	12	51	41.3	31.5	14.3
D87912-16-12	3/4"	16	51	41.3	31.5	14.3
D87912-12-16	1"	12	55.5	47.6	38	14.3
D87912-16-16	1"	16	55.5	47.6	38	14.3
D87912-20-16	1"	20	55.5	47.6	38	14.3
D87912-16-20	1.1/4"	16	65	54	42	14.3
D87912-20-20	1.1/4"	20	65	54	42	14.3
D87912-20-24	1.1/2"	20	75	63.5	50	14.3
D87912-24-24	1.1/2"	24	75	63.5	50	14.3
D87912-24-32	2"	24	84	79.4	61.5	14.3
D87912-32-32	2"	32	85	79.4	61.5	14.3

NOTA

1. Para uso con mangueras trenzadas
2. Para uso con manguera espiralada la referencia cambia el ULTIMO digito

A = Alto corte conexión - C1 = Diámetro Brida - D1 = Diámetro Cuello - L1 = Alto cabeza

D87992 ISO 12151-3 - SAE J516

FLANCHE CODO 90° SAE 9000 PSI SUPER CAT PARA MANGUERA R13

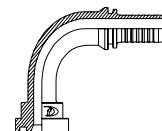

REFERENCIA	DIAMETRO NOMINAL FLANCHE	DIAMETRO MANGUERA	DIMENSIONES				
		GUION	A	C1	D1	H	L1
D87992-12-12	3/4"	12	57	41.3	32	59	14.3
D87992-12-16	1"	12	57	47.6	38	62	14.3
D87992-16-16	1"	16	69	47.6	38	73	14.3
D87992-20-16	1"	20	83	47.6	38	85	14.3
D87992-16-20	1.1/4"	16	69	54	44	73.5	14.3
D87992-20-20	1.1/4"	20	83	54	44	85.5	14.3
D87992-20-24	1.1/2"	20	83	63.5	44	90	14.3
D87992-24-24	1.1/2"	24	94	63.5	51	100	14.3
D87992-24-32	2"	24	94	79.4	67	100	14.3
D87992-32-32	2"	32	122	79.4	67	124	14.3

NOTA

1. Para uso con mangueras trenzadas
2. Para uso con manguera espiralada la referencia cambia el ULTIMO digito

A = Alto corte conexión - C1 = Diámetro Brida - D1 = Diámetro Cuello - H = Longitud de Caída - L1 = Alto cabeza

*D88111

FLANCHE RECTO KOMATSU (JIS)

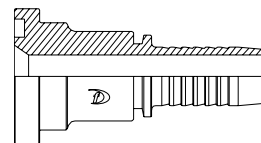

REFERENCIA	HILOS	DIAMETRO MANGUERA		DIMENSIONES			
		DN	GUION	A	C1	D1	L1
D88111-08-10	5/8"	12	08	45	34.2	28	6.7
D88111-10-10	5/8"	16	10	46	34.2	27.8	6.7
D88111-12-10	5/8"	20	12	46	34.2	27.8	6.7

NOTA

1. Para uso con mangueras trenzadas
2. Para uso con manguera espiralada la referencia cambia el ULTIMO digito

A = Alto corte conexión - C1 = Diámetro Brida - D1 = Diámetro Cuello - L1 = Alto cabeza

*D88141

FLANCHE CODO 45° KOMATSU (JIS)

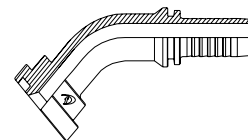

REFERENCIA	HILOS	DIAMETRO MANGUERA		DIMENSIONES				
		DN	GUION	A	C1	D1	H	L1
D88141-08-10	5/8"	12	08	58.9	34.2	27.8	24	6.7
D88141-10-10	5/8"	16	10	60.5	34.2	27.8	26	6.7
D88141-12-10	5/8"	20	12	76.2	34.2	27.8	28.8	6.7

NOTA

1. Para uso con mangueras trenzadas
2. Para uso con manguera espiralada la referencia cambia el ULTIMO digito

A = Alto corte conexión - C1 = Diámetro Brida - D1 = Diámetro Cuello - H = Longitud de Caída - L1 = Alto cabeza

*D88191

FLANCHE CODO 90° KOMATSU (JIS)

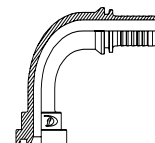

REFERENCIA	HILOS	DIAMETRO MANGUERA		DIMENSIONES				
		DN	GUION	A	C1	D1	H	L1
D88191-08-10	5/8"	12	08	42	34.2	27.8	48	6.7
D88191-10-10	5/8"	16	10	51	34.2	27.8	52.5	6.7
D88191-12-10	5/8"	20	12	57	43.2	27.8	62	6.7

NOTA

1. Para uso con mangueras trenzadas
2. Para uso con manguera espiralada la referencia cambia el ULTIMO digito

A = Alto corte conexión - C1 = Diámetro Brida - D1 = Diámetro Cuello - H = Longitud de Caída - L1 = Alto cabeza

*NOTA: Para mangueras espiraladas la referencia en acoples, cambie el ultimo digito de 1 a 2.

*D28611D

HEMBRA JIS ASIENTO (30°) METRICA DOBLE HEXAGONO

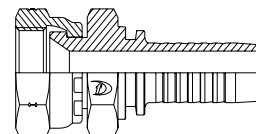

REFERENCIA	HILOS	DIAMETRO MANGUERA	DIMENSIONES			
		GUION	A	C	S1	S2
D28611D-04-14	M14 x1.5	04	22	10	14	19
D28611D-06-14	M14 x1.5	06	24	10	17	19
D28611D-04-16	M16 x1.5	04	24.5	11	17	22
D28611D-05-16	M16 x1.5	05	25	11	19	22
D28611D-06-16	M16 x1.5	06	25	11	19	22
D28611D-06-18	M18 x1.5	06	25.5	12	22	24
D28611D-08-18	M18 x1.5	08	25.5	12	22	24
D28611D-08-20	M20 x1.5	08	27.5	12.5	27	27
D28611D-08-22	M22 x1.5	08	28	12.5	27	27
D28611D-08-24	M24 x1.5	08	29	12	30	30
D28611D-10-24	M24 x1.5	10	29.5	12	30	30
D28611D-12-30	M30 x1.5	12	31	17	36	36
D28611D-12-33	M33 x1.5	12	32	20	36	41
D28611D-16-33	M33 x1.5	16	32	20	36	41
D28611D-20-36	M36 x1.5	20	36.5	18	46	46
D28611D-24-42	M42 x1.5	24	38	18.5	50	50

NOTA

1. Para uso con mangueras trenzadas
2. Para uso con manguera espiralada la referencia cambia el ULTIMO digito

A = Alto corte conexión - C = Alto de la Cuerda - S1 = Diámetro Hexágono - S2 = Diámetro Hexágono Cabeza

***D28641**

HEMBRA CODO 45° SELLO JIS ASIENTO (30°) METRICA

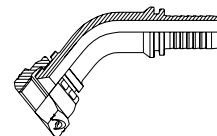

REFERENCIA	HILOS	DIAMETRO MANGUERA	DIMENSIONES			
		GUION	A	C	H	S2
D28641-04-14	M14 x1.5	04	34.5	10	16.5	19
D28641-06-18	M18 x1.5	06	40	12	19	24
D28641-08-22	M22 x1.5	08	48	12.5	22	27
D28641-10-24	M24 x1.5	10	55	12	25.5	30
D28641-12-30	M30 x1.5	12	61	17	28.5	36
D28641-16-33	M33 x1.5	16	69.5	20	33	41
D28641-20-36	M36 x1.5	20	83	18	39	46
D28641-24-42	M42 x1.5	24	86.5	18.5	43	50

NOTA

1. Para uso con mangueras trenzadas
2. Para uso con manguera espiralada la referencia cambia el ULTIMO digito

A = Alto corte conexión - C = Alto de la Cuerda - H = Longitud de Caída - S2 = Diámetro Hexágono Cabeza

***D28691**

HEMBRA CODO 90° SELLO JIS ASIENTO (30°) METRICA

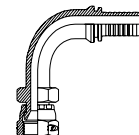

REFERENCIA	HILOS	DIAMETRO MANGUERA	DIMENSIONES			
		GUION	A	C	H	S2
D28691-04-14	M14 x1.5	04	28.5	10	30	19
D28691-06-18	M18 x1.5	06	34	12	37.5	24
D28691-08-22	M22 x1.5	08	42	12.5	45	27
D28691-10-24	M24 x1.5	10	51	12	51	30
D28691-12-30	M30 x1.5	12	57	17	58	36
D28691-16-33	M33 x1.5	16	69	20	70	41
D28691-20-36	M36 x1.5	20	83	18	83	46
D28691-24-42	M42 x1.5	24	94	18.5	93.5	50

NOTA

1. Para uso con mangueras trenzadas
2. Para uso con manguera espiralada la referencia cambia el ULTIMO digito

A = Alto corte conexión - C = Alto de la Cuerda - H = Longitud de Caída - S2 = Diámetro Hexágono Cabeza

*NOTA: Para mangueras espiraladas la referencia en acoples, cambie el ultimo digito de 1 a 2.

*D29611D JIS B8363

HEMBRA SELLO JIS GAS ASIENTO (30°) DOBLE HEXAGONO

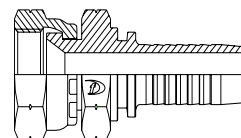

REFERENCIA	HILOS	DIAMETRO MANGUERA	DIMENSIONES			
		GUION	A	C	S1	S2
D29611D-04-04	G1/4" x19	21.5	04	8	14	17
D29611D-06-06	G3/8" x19	23.5	06	9	17	22
D29611D-08-08	G1/2" x14	28	08	10.5	27	27
D29611D-10-10	G5/8" x14	28.5	10	11.5	30	20
D29611D-12-12	G3/4" x14	32	12	12.5	32	32
D29611D-16-16	G1" x11	35	16	14	41	41
D29611D-20-20	G1.1/4" x11	37	20	15.5	50	50
D29611D-24-24	G1.1/2" x11	37.5	24	17	50	55

NOTA

1. Para uso con mangueras trenzadas
2. Para uso con manguera espiralada la referencia cambia el ULTIMO digito

A = Alto corte conexión - C = Alto de la Cuerda - S1 = Diámetro Hexágono - S2 = Diámetro Hexágono Cabeza

*D29641 JIS B 8363

HEMBRA CODO 45° SELLO JIS GAS ASIENTO (30°)

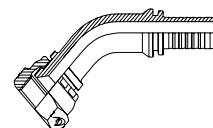

REFERENCIA	HILOS	DIAMETRO MANGUERA	DIMENSIONES			
		GUION	A	C	S1	S2
D29641-04-04	G1/4" x19	04	34.5	8	16.5	17
D29641-06-06	G3/8" x19	06	40	9	19	22
D29641-08-08	G1/2" x14	08	48	10.5	22	27
D29641-10-10	G5/8" x14	10	55	11.5	25.5	20
D29641-12-12	G3/4" x14	12	61	12.5	28.5	32
D29641-16-16	G1" x11	16	69.5	14	33	41
D29641-20-20	G1.1/4" x11	20	83	15.5	39	50
D29641-24-24	G1.1/2" x11	24	86.5	17	43	55

NOTA

1. Para uso con mangueras trenzadas
2. Para uso con manguera espiralada la referencia cambia el ULTIMO digito

A = Alto corte conexión - C = Alto de la Cuerda - S1 = Diámetro Hexágono - S2 = Diámetro Hexágono Cabeza

*NOTA: Para mangueras espiraladas la referencia en acoples, cambie el ultimo digito de 1 a 2.

*D29691 JIS B 8363

HEMBRA CODO 90° SELLO JIS GAS ASIENTO (30°)

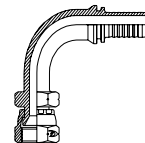

REFERENCIA	HILOS	DIAMETRO MANGUERA	DIMENSIONES			
		GUION	A	C	H	S2
D29691-04-04	G1/4" x19	04	28.5	8	30	17
D29691-06-06	G3/8" x19	06	34	9	37.5	22
D29691-08-08	G1/2" x14	08	42	10.5	45	27
D29691-10-10	G5/8" x14	10	51	11.5	51	20
D29691-12-12	G3/4" x14	12	57	12.5	58	32
D29691-16-16	G1" x11	16	69	14	70	41
D29691-20-20	G1.1/4" x11	20	83	15.5	83	50
D29691-24-24	G1.1/2" x11	24	94	17	93.5	55

NOTA

1. Para uso con mangueras trenzadas
2. Para uso con manguera espiralada la referencia cambia el ULTIMO digito

A = Alto corte conexión - C = Alto de la Cuerda - H = Longitud de Caída - S2 = Diámetro Hexágono Cabeza

*D60011

MACHO RECTO STAPLE-LOCK MINERIA

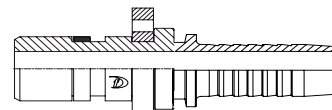

REFERENCIA	DIAMETRO MANGUERA		DIMENSIONES			
	DN	GUION	A	C	J	K
D60011-04-04	6	04	31	25	15	11
D60011-05-05	8	05	33.5	26	18	13
D60011-06-06	10	06	33	26	18	15
D60011-06-08	10	06	33.5	26	22	18
D60011-08-08	12	08	34	26	22	18
D60011-10-10	16	10	39	30	25	20
D60011-12-12	20	12	40.5	31	28	24
D60011-14-16	22	14	41	31	35	30
D60011-16-16	25	16	42	31	35	30

NOTA

1. Para uso con mangueras trenzadas
2. Para uso con manguera espiralada la referencia cambia el ULTIMO digito

A = Alto corte conexión - C = Alto de la Cuerda - J = Diámetro Cuerpo - K = Diámetro Cabeza

*NOTA: Para mangueras espiraladas la referencia en acoples, cambie el ultimo digito de 1 a 2.

D67011 SAE J1467

MACHO RECTO STAPLE-LOCK MINERIA

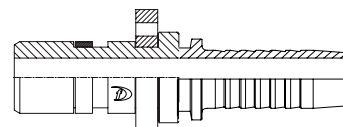

REFERENCIA	DIAMETRO MANGUERA		TORNILLO	DIMENSIONES			
	DN	GUION		A	C	J	K
D67011-04-04	6	04	O06.0 x2.0	34	28	14.9	9.9
D67011-06-06	10	06	O10.0 x2.0	35	28	19.9	13.9
D67011-08-08	12	08	O13.0 x2.5	36	28	23.9	17.9
D67011-12-12	20	12	O19.0 x2.5	37.5	28	28.9	23.9
D67011-16-16	25	16	O25.0 x2.5	44	33	38.8	30.9
D67011-20-20	32	20	O33.0 x2.5	44	33	45.9	37.9
D67011-24-24	40	24	O40.0 x3.0	47.5	36.6	54.9	46.9
D67011-32-32	50	32	O50.0 x3.0	47.5	36.3	63.9	55.9

NOTA

1. Para uso con mangueras trenzadas
2. Para uso con manguera espiralada la referencia cambia el ULTIMO digito

A = Alto corte conexión - C = Alto de la Cuerda - J = Diámetro Cuerpo - K = Diámetro Cabeza

*D70011 DIN 7642

BANJO METRICO

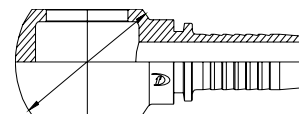

REFERENCIA	TORNILLO	DIAMETRO MANGUERA	DIMENSIONES			
		GUION	A	d	D2	H2
D70011-04-10	M10 x1	04	24.5	10.2	20	12.3
D70011-04-12	M12 x1.5	04	24.5	12.1	22	12.3
D70011-05-12	M12 x1.5	05	27	12.1	22	12
D70011-06-12	M12 x1.5	06	27	12.1	20	12
D70011-04-14	M14 x1.5	04	26.5	14.1	24	14
D70011-05-14	M14 x1.5	05	25	14.1	24	14
D70011-06-14	M14 x1.5	06	27	14.1	24	14
D70011-04-16	M16 x1.5	04	30.5	16.1	28	16
D70011-06-16	M16 x1.5	06	29	16.1	28	16
D70011-04-18	M18 x1.5	04	31.5	18.1	28	20
D70011-06-18	M18 x1.5	06	30	18.1	32	20
D70011-08-18	M18 x1.5	08	25	18.1	32	20
D70011-08-22	M22 x1.5	08	36	22.2	39	26
D70011-10-22	M22 x1.5	10	41	22.2	39	25
D70011-12-26	M26 x1.5	12	41	26.2	46	30

NOTA

1. Para uso con mangueras trenzadas
2. Para uso con manguera espiralada la referencia cambia el ULTIMO digito

A = Alto corte conexión - d = Diámetro pasador - D2 = Diámetro Diagonal - H2 = Alto Cabeza

*NOTA: Para mangueras espiraladas la referencia en acoples, cambie el ultimo digito de 1 a 2.

D700M DIN 7643 PASADOR METRICO

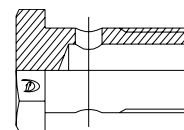

REFERENCIA	TORNILLO	DIMENSIONES			
		A2	B2	C2	S1
D700M-10	M10 x1	21	4.5	5	14
D700M-12	M12 x1.5	26	6	6	17
D700M-14	M14 x1.5	26	8	6	19
D700M-16	M16 x1.5	33	8	6	22
D700M-18	M18 x1.5	33	11	7	24
D700M-22	M22 x1.5	39	14	8	27
D700M-26	M26 x1.5	45	18	8	32

NOTA

1. Para uso con mangueras trenzadas
2. Para uso con manguera espiralada la referencia cambia el ULTIMO digito

A2 = Largo del Perno - **B2** = Paso Flujo - **C2** = Alto Cabeza Hexagono - **S1** = Diámetro Hexágono

D72011 BANJO BSP

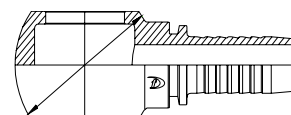

REFERENCIA	TORNILLO	DIAMETRO MANGUERA	DIMENSIONES			
		GUION	A2	d	D2	H2
D72011-04-02	G1/8" x28	04	26.5	9.8	22	16
D72011-03-04	G1/4" x19	03	26.5	13.3	24	15
D72011-04-04	G1/4" x19	04	26.5	13.3	24	15
D72011-06-04	G1/4" x19	06	26.5	13.3	24	15
D72011-05-06	G3/8" x19	05	31	16.7	32	20
D72011-06-06	G3/8" x19	06	31	16.7	32	20
D72011-08-06	G3/8" x19	08	30	16.7	32	20
D72011-06-08	G1/2" x14	06	29	21	39	25
D72011-08-08	G1/2" x14	08	29	21	39	25
D72011-10-08	G1/2" x14	10	36	23.1	39	25
D72011-12-12	G3/4" x14	12	41	26.5	48	31
D72011-16-16	G1" x11	16	56.5	33.3	60	42

NOTA

1. Para uso con mangueras trenzadas
2. Para uso con manguera espiralada la referencia cambia el ULTIMO digito

A2 = Largo del Perno - **d** = Diámetro pasador - **D2** = Diámetro Diagonal - **H2** = Alto Cabeza

D720B PASADOR BSP

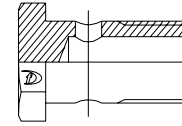

REFERENCIA	TORNILLO	DIMENSIONES			
		A2	B2	C2	S1
D720B-02	G1/8" x28	21	4.5	5	14
D720B-04	G1/4" x19	26	6	6	17
D720B-06	G3/8" x19	26	8	6	19
D720B-08	G1/2" x14	33	8	6	22
D720B-12	G3/4" x14	45	18	8	32

NOTA

1. Para uso con mangueras trenzadas
2. Para uso con manguera espiralada la referencia cambia el ULTIMO digito

A2 = Largo del Perno - **B2** = Paso Flujo - **C2** = Alto Cabeza Hexagono - **S1** = Diámetro Hexágono

D15611SW SAE J 516 MACHO GIRATORIO NPT ASIENTO 30°

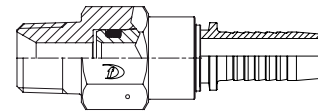

REFERENCIA	HILOS	DIAMETRO MANGUERA	DIMENSIONES		
		GUION	A	S1	S2
D15611SW-04-04	Z1/4" x18	04	45	17	17
D15611SW-06-06	Z3/8" x18	06	47	19	19
D15611SW-08-08	Z1/2" x14	08	51	24	19

NOTA

1. Para uso con mangueras trenzadas
2. Para uso con manguera espiralada la referencia cambia el ULTIMO digito

A = Alto corte conexión - **S1** = Diámetro Hexágono - **S2** = Diámetro Hexágono Cabeza

D15691KSW

MACHO CODO 90° GIRATORIO NPT ASIENTO 30°

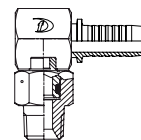

REFERENCIA	HILOS	DIAMETRO MANGUERA		DIMENSIONES			
		DN	GUION	A	H	S1	S2
D15691KSW-04-04	Z1/4" x18	6	04	25	59.5	16	19
D15691KSW-06-06	Z3/8" x18	10	06	25	64.5	16	22
D15691KSW-08-08	Z1/2" x14	12	08	28.5	71.5	19	27
D15691KSW-12-12	Z3/4" x14	20	12	36	76.9	27	32

NOTA

1. Para uso con mangueras trenzadas
2. Para uso con manguera espiralada la referencia cambia el ULTIMO digito

A = Alto corte conexión - H = Longitud de Caída - S1 = Diámetro Hexágono - S2 = Diámetro Hexágono Cabeza

D16011SW SAE J 516 /J 514

MACHO GIRATORIO CON O-RING TIPO BOSS

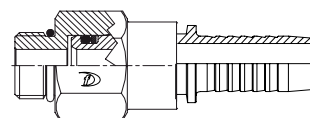

REFERENCIA	HILOS	DIAMETRO MANGUERA		O-RING	DIMENSIONES	
		DN	GUION		A	S2
D16011SW-06-08	3/4" x16	10	06	O908	57.5	27
D16011SW-08-08	3/4" x16	12	08	O908	58	27
D16011SW-08-10	7/8" x14	12	08	O910	59.5	27
D16011SW-10-10	7/8" x14	16	10	O910	60.1	27
D16011SW-12-12	1.1/16" x12	20	12	O912	64.9	32

NOTA

1. Para uso con mangueras trenzadas
2. Para uso con manguera espiralada la referencia cambia el ULTIMO digito

A = Alto corte conexión - S2 = Diámetro Hexágono Cabeza

D16091KSW

MACHO CODO 90° GIRATORIO CON O-RING TIPO BOSS

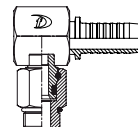

REFERENCIA	HILOS	DIAMETRO MANGUERA		O-RING	DIMENSIONES			
		DN	GUION		A	H	S1	S2
D16091KSW-06-08	3/4" x16	10	06	O908	28.5	63.5	19	27
D16091KSW-08-08	3/4" x16	12	08	O908	28.5	63.5	19	27
D16091KSW-06-10	7/8" x14	10	06	O910	28.5	65	19	27
D16091KSW-08-10	7/8" x14	12	08	O910	28.5	65	19	27
D16091KSW-10-10	7/8" x14	16	10	O910	30.5	65.5	22	27

NOTA

1. Para uso con mangueras trenzadas
2. Para uso con manguera espiralada la referencia cambia el ULTIMO digito

A = Alto corte conexión - H = Longitud de Caída - S1 = Diámetro Hexágono - S2 = Diámetro Hexágono Cabeza

D90011

DOBLE CONECTOR (UNIÓN MANGUERA)

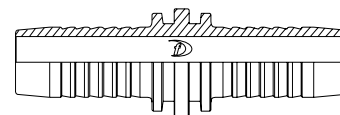

REFERENCIA	DIAMETRO MANGUERA		DIMENSIONES
	DN	GUION	L
D90011-04	6	04	69
D90011-05	8	05	69
D90011-06	10	06	73
D90011-08	12	08	77
D90011-10	16	10	83
D90011-12	20	12	93
D90011-16	25	16	114
D90011-20	32	20	132
D90011-24	40	24	162
D90011-32	50	32	170

NOTA

Para manguera espiralada

L = Largo

D10011N

ESPIGA SOLDABLE (SALVAVIDAS)

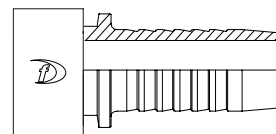

REFERENCIA	DIAMETRO MANGUERA	DIMENSIONES	
	GUION	C3	D3
D10011N-03-03	03	5	4.2
D10011N-04-04	04	6.5	6.7
D10011N-05-05	05	8	8.3
D10011N-06-06	06	10	10
D10011N-08-08	08	13	13.1
D10011N-10-10	10	16	16.2
D10011N-12-12	12	19.5	19.2
D10011N-16-16	16	26	25.5
D10011N-20-20	20	32	32.5
D10011N-24-24	24	38.5	38.5
D10011N-32-32	32	51	51.5

NOTA

1. Para uso con mangueras trenzadas
2. Para uso con manguera espiralada la referencia cambia el ULTIMO digito

C3 = Caja de Cuello - **D3** = Diámetro Espigo

D00518

FERRUL REUSABLE PARA MANGUERA SAE 100 R5

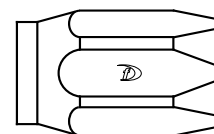

REFERENCIA	DIAMETRO MANGUERA	DIMENSIONES	
	GUION	L	S1
D00518-04	04	28	17
D00518-05	05	30.5	19
D00518-06	06	33	22
D00518-08	08	42	24
D00518-10	10	45.5	30
D00518-12	12	53.5	32
D00518-16	16	42	36
D00518-20	20	44.5	46
D00518-24	24	47	50
D00518-32	32	57	65

L = Largo - **S1** = Diámetro Hexágono

D17818-R5 SAE J513
MACHO SAE ASIENTO (45°) PARA R5

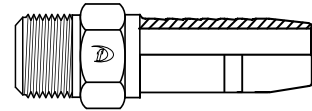

REFERENCIA	HILOS	DIAMETRO MANGUERA	DIMENSIONES	
		GUION	A	S2
D17818-06-06 (R5)	5/8" x18	06	33.7	17
D17818-08-08 (R5)	3/4" x16	08	42	22
D17818-12-12 (R5)	1.1/16" x14	12	51	30

A = Alto corte conexión - S2 = Diámetro Hexágono Cabeza

D27818D-R5 SAE J513
HEMBRA SAE ASIENTO (45°) PARA R5

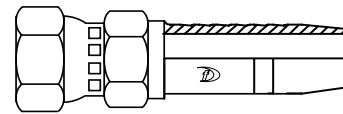

REFERENCIA	HILOS	DIAMETRO MANGUERA	DIMENSIONES			
		GUION	A	C	S1	S2
D27818D-04-04 (R5)	7/16" x20	04	22	9	14	17
D27818D-05-05 (R5)	1/2" x20	05	25.4	9	14	17
D27818D-06-06 (R5)	5/8" x18	06	26	11.3	17	22
D27818D-08-08 (R5)	3/4" x16	08	31.5	10.5	22	24
D27818D-10-10 (R5)	7/8" x14	10	34	12	27	27
D27818D-12-12 (R5)	1.1/16" x14	12	37	14.3	32	32

A = Alto corte conexión - C = Alto de la Cuerda - S1 = Diámetro Hexágono - S2 = Diámetro Hexágono Cabeza



REFERENCIA	CAPACIDAD DIAMETRO MM.	PRESSURE		KW	VOLTAJE	TONELADAS	CAPACIDAD TANQUE LITROS	NÚMERO DADOS
		MPA	PSI					
DSG150-3	6 a 150	48	6961	7,5	380	1130	58	19
DSG75-3	6 a 76	48	6961	7,5	380	400 a 640	57,6	10
DSG250A-3	6 a 51	20	2900	4	380	407	10	10
DSG250B-3	6 a 51	31,5	4568	4	380	640	10	10
DX68-2	6 a 51	31,5	4568	3	220	400	2,5/ 5	10
DX68-3	6 a 51	31,5	4568	3	380	400	2,5/ 5	10
DSG51B-3	6 a 51	20	2900	3,8	380	407	10	10
DSG51A-2	6 a 51	20	2900	3	220	407	10	10
DSG51A-3	6 a 51	20	2900	3	380	407	10	10

NOTAS:

- 1- Al confirmar su pedido debe indicar el voltaje requerido.
- 2- La maquina se despacha con los set de dados indicados en su guía.
- 3- La maquina se despacha con su respectiva calibración y verificación de fabrica.
- 4- La maquina se despacha con su respectivo caja de madera.
- 5- La maquina lleva sus instrucciones de uso.
- 6- El personal de fabrica estará listo para asesorarlo en su instalación e instrucciones de uso.

MAQUINAS DE CORTE DE MANGUERAS

Maquinas de corte de mangueras con seguridad
CODIGO: D388561000
REFERENCIA: DJQQ51



- *Corte refrigerada, minimo de humos y desechos.
- *Maquina robusta y operación segura.
- *Capacidad de manguera 4-51mm
- *2 "4-espiral 1" 6-espiral
- *Diámetro de la hoja: 350mm
- *La presión de aceite estándar: 2.5Mpa
- *Tensión nominal: 7,5 kW 380V-3ph (opcionales voltajes bajo pedido)
- *Dimensiones:
Largo: 800 mm Ancho: 550 mm Altura: 990 mm
Peso (sin aceite): 150KGS

Maquinas de corte de mangueras con seguridad
CODIGO: D388562000
REFERENCIA : DJQ51



- *Corte refrigerada, minimo de humos y desechos.
- *Maquina robusta y operación segura.
- *Capacidad de manguera 4-51mm
- *1-1/2 "2-espiral 1" 4-espiral
- *Diámetro de la hoja: 325mm
- *La presión de aceite estándar: 2.5Mpa
- *Tensión nominal: 380V 2.2KW-3ph (opcionales voltajes bajo pedido)
- *Dimensiones:
Largo: 600 mm Ancho: 420 mm Altura: 510 mm
Peso (sin aceite): 100kgs

ANALISIS COMPARATIVO ENTRE LOS DIFERENTES TIPOS DE SELLOS.

Para hacer una mejor selección entre los grupos de sellos, damos algunos puntos clave a continuación.

El adaptador es una interface para conectar un número de roscas sin compatibilidad directa. Los adaptadores pueden ser clasificados en grupos (NPTF,JIC,ORFS,BSPP,DIN etc.) Dependiendo del tipo de configuración de su terminal o sello.

Los adaptadores Dayflex® están fabricados de una pieza sólida de acero, tanto en rectos, como en cruz, a 45°, 90° y tees, Las geometrías son forjadas y luego mecanizadas. Este proceso elimina posibles fugas en los adaptadores que son soldados.

Los O-rings suministrados son estándar, en los adaptadores de la gama que llevan O-Ring son en nitrilo 90 +- Shore –A- que son los apropiados para fluidos hidráulicos con base en petróleo y no inflamables con base agua.

Nuestros productos tienen un zincado plata para proporcionar protección contra la corrosión, respondiendo a los estándares SAE e ISO y para cumplir con el método de evaluación con salmuera ASTM-B177, ISO 9227.

CARACTERISTICAS

		JIC	BSP	ORFS
COMPORTAMIENTO	Capacidad de presión	Media a Alta	Media a Alta	Muy alta
	Confiabilidad de sellado	Buena	Buena	Excelente
	Resistencia a la vibración en sistemas rígidos	Buena	Muy buena	Excelente
ENSAMBLE		Muy bueno	Bueno	Excelente
		Fácil y rápida preparación del tubo y buena facilidad de instalación	Fácil y rápida preparación del tubo y buena facilidad de instalación	Fácil y rápida preparación del tubo y buena facilidad de instalación
TIPO DE SELLADO		Metal a Metal	Metal a Metal	Sellado elastomérico
RESISTENCIA A TEMPERATURA	Sin O-ring	(-50°C +260°C)	(-50°C +260°C)	NO DISPONIBLE
	Con O-ring	NO DISPONIBLE**	(-35°C +125°C)	(-35°C +125°C)
USO ACTUAL		Usado en todo el mundo	Usado principalmente en Japón y los países de la Unión Británica	Usado principalmente en Norteamérica, ganando importancia en Europa y Japón
ESPECIFICACIONES		SAE J514 e ISO 8431-2	BS 5200 e ISO 8434-6	SAE J1453 e ISO 8431-3

SELLO O TERMINAL SAE J514, 37° FLARE JIC

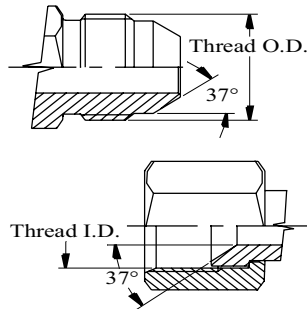

Este tipo de conexión es muy común en circuitos hidráulicos. Tanto el macho como la hembra tienen un asiento o un ángulo de 37° y cuando las roscas están unidas entre sí dan lugar al sellado. La conexión está sometida mecánicamente por la rosca.

Nota importante: Los diámetros de las roscas -04, -05, -08 y -10 en los sellos JIC (37°) y SAE (45°) es la misma pero se debe tener el respectivo cuidado para no confundirlos por el ángulo de asiento diferente entre los sellos.

TAMAÑO	GUIÓN	TAMAÑO ROSCA NOMINAL	ROSCA MACHO		ROSCA HEMBRA		PRESION DE TRABAJO		TORQUE SUGERIDO	
			mm	pulg	mm	pulg	bar	psi	min.	max.
1/4"	-04	7/16" - 20	11.2	0.44	9.9	0.39	310	4490	9	11
5/16"	-05	1/2" - 20	12.7	0.50	11.4	0.45	310	4490	13	16
3/8"	-06	9/16" - 18	14.2	0.56	12.9	0.51	280	4060	18	24
1/2"	-08	3/4" - 16	19.0	0.75	17.0	0.67	280	4060	33	38
5/8"	-10	7/8" - 14	22.3	0.88	20.3	0.80	210	3040	50	59
3/4"	-12	1.1/16" - 12	26.9	1.06	24.9	0.98	210	3040	69	77
7/8"	-14	1.3/16" - 12	30.0	1.18	27.7	1.09	210	3040	85	96
1"	-16	1.5/16" - 12	33.3	1.31	31.0	1.22	180	2610	96	109
1.1/4"	-20	1.5/8" - 12	41.4	1.63	39.1	1.54	140	2030	129	142
1.1/2"	-24	1.7/8" - 12	47.7	1.88	45.5	1.79	100	1450	159	170

SELLO O TERMINAL BSPP ISO 228-PT & BSPT- ISO 7-PT

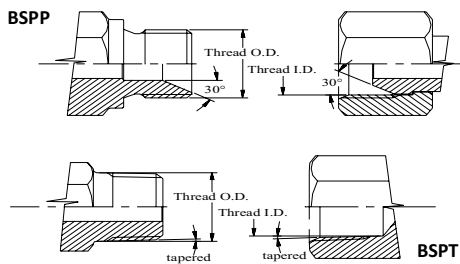

La conexión británica tiene dos tipos de rosca: BSPP y BSPT.

La cuerda BSPP es paralela y el macho tiene un asiento de 30° ensanchado, el cual sella con una hembra BSP con su respectivo asiento de 30°, los hilos sostienen la conexión mecánicamente.

La rosca macho BSPT es cónica y usualmente encaja con otra rosca similar. El sellado tiene lugar por la distorsión de los hilos razón por la cual se recomienda un sellante.

Los BSPP/BSPT son similares a las conexiones americanas por su ángulo de asiento NPSM/NPTF excepto por el número de hilos de la rosca que difieren entre sí.

TAMAÑO	GUIÓN	TAMAÑO ROSCA NOMINAL	ROSCA MACHO		ROSCA HEMBRA		PRESION DE TRABAJO		TORQUE SUGERIDO	
			mm	pulg	mm	pulg	bar	psi	min.	max.
1/8"	-02	1/8" - 28	10.3	0.41	9.4	0.37	350	5070	7	9
1/4"	-04	1/4" - 19	13.7	0.54	12.4	0.49	350	5070	11	15
3/8"	-06	3/8" - 19	17.3	0.68	15.7	0.62	350	5070	18	24
1/2"	-08	1/2" - 14	21.3	0.84	19.3	0.76	315	4560	33	40
5/8"	-10	5/8" - 14	22.9	0.90	21.1	0.83	315	4560	40	48
3/4"	-12	3/4" - 14	26.9	1.06	24.9	0.98	250	3620	59	68
1"	-16	1" - 11	33.3	1.31	31.5	1.24	200	2900	77	88
1.1/4"	-20	1.1/4" - 11	42.2	1.66	40.1	1.58	160	2320	111	125
1.1/2"	-24	1.1/2" - 11	48.3	1.90	46.2	1.82	125	1810	155	170

SELLO O TERMINAL SAE J1453, O-RING FACE SEAL -ORFS

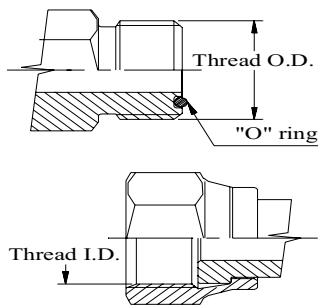

Esta conexión ofrece el mejor control de fugas en los sellos hidráulicos disponible en el mercado en la actualidad y está diseñada para trabajar a altas presiones.

El macho tiene un hilo recto y un O-ring en la cara mientras que la hembra tiene un hilo recto con una cara plana mecanizada. El sellado se forma por la compresión del O-ring en la cara plana de la hembra y la conexión es mecánicamente sostenida en su lugar por la rosca.

TAMAÑO	GUIÓN	TAMAÑO ROSCA NOMINAL	ROSCA MACHO		ROSCA HEMBRA		PRESION DE TRABAJO		TORQUE SUGERIDO		DIMENSIÓN O- RING
			mm	pulg	mm	pulg	bar	psi	min.	max.	
1/4"	-04	9/16" - 18	14.2	0.56	12.9	0.51	420	6090	11	13	7.65x1.78
3/8"	-06	11/16" - 16	17.3	0.68	16.0	0.63	420	6090	18	20	9.25x1.78
1/2"	-08	13/16" - 16	20.6	0.81	19.0	0.75	400	5800	32	37	12.42x1.78
5/8"	-10	1" - 14	25.4	1.00	23.6	0.93	400	5800	46	50	15.6x1.78
3/4"	-12	1.3/16" - 12	30.0	1.18	27.8	1.10	400	5800	69	74	18.77x1.78
1"	-16	1.7/16" - 12	36.6	1.44	34.5	1.36	350	5070	92	103	23.52x1.78
1.1/4"	-20	1.11/16" - 12	42.7	1.68	40.6	1.60	270	3910	125	140	29.87x1.78
1.1/2"	-24	2" - 12	50.8	2.00	48.8	1.92	210	3040	155	170	37.82x1.78

SELLO O TERMINAL NPTF SAE J476 – ANSI B1.20.3 NPSM ANSI B1.20.1

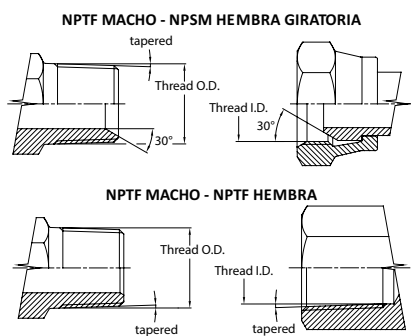

Las roscas NPTF NPSM son conexiones Americanas que tienen un ángulo de asiento de 60° entre los hilos.

El macho NPTF y la rosca hembra son cónicos y controlan el trucamiento para asegurar el contacto metal con metal entre las crestas y raíz y crear la estanqueidad en la rosca.

El macho NPTF tiene un ángulo cónico de asiento de 30° también para la unión de la hembra NPTF/NPSM (rosca cilíndrica). En este caso la estanqueidad se realiza con el contacto metal con metal entre los conos.

TAMAÑO PULGADAS	MÓDULO	TAMAÑO ROSCA NOMINAL	ROSCA MACHO		ROSCA HEMBRA		PRESION DE TRABAJO		TORQUE SUGERIDO
			mm	pulg	mm	pulg	bar	psi	min.
1/8"	-02	1/8" - 27	10.4	0.41	9.2	0.36	345	5000	15
1/4"	-04	1/4" - 18	14.0	0.55	12.2	0.48	345	5000	22
3/8"	-06	3/8" - 18	17.3	0.68	15.5	0.61	275	4000	30
1/2"	-08	1/2" - 14	21.6	0.85	19.2	0.76	240	3500	40
3/4"	-12	3/4" - 14	26.9	1.06	24.6	0.97	155	2250	52
1"	-16	1" - 11.5	33.8	1.33	30.7	1.21	135	2000	66
1.1/4"	-20	1.1/4" - 11.5	42.4	1.67	39.4	1.55	110	1625	74
1.1/2"	-24	1.1/2" - 11.5	48.5	1.91	45.5	1.79	85	1250	89

MEDIDAS DE LAS ROSCAS UNF-UN / SAE J475 – J1926

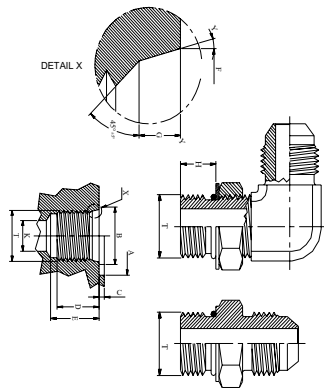

INFORMACIÓN TÉCNICA

Sellado con O-ring

- Si la superficie de la cara de la rosca esta mecanizada, las dimensiones A y C no necesitan ser aplicadas ya que los requerimientos de la superficie (Ra min 3,2) pueden evitar el daño al O-ring durante la instalación.
- C es la máxima profundidad recomendada para permitir un apropiado encaje del acople o la contratuerca.
- La superficie expuesta (dimensión B) debe ser alineada (0,2 mm) con las roscas
- El diámetro F debe ser concéntrico (0,1 mm) con las roscas
- La superficie en la longitud G necesita Ra 3,2 min para evitar daño en el O-ring durante la instalación.

Medida Rosca	7/16" -20	1/2" -20	9/16" -18	3/4" -16	7/8" -14	1.1/16" -12	1.3/16" -12	1.5/16" -12	1.5/8" -12	1.7/8" -12
T Nom.	0.437	0.500	0.563	0.750	0.875	1.063	1.187	1.313	1.625	1.875
C Max.	0.06	0.06	0.06	0.09	0.09	0.09	0.09	0.12	0.12	0.12
D Min.	0.47	0.47	0.51	0.59	0.67	0.79	0.79	0.79	0.79	0.79
E Min.	0.55	0.55	0.63	0.71	0.79	0.94	0.94	0.94	0.94	0.94
K Min.	0.20	0.24	0.30	0.39	0.49	0.63	0.71	0.83	1.06	1.30
A Min.	0.83	0.91	0.98	1.18	1.34	1.61	1.77	1.93	2.28	2.56
B Min.	0.59	0.63	0.71	0.87	1.02	1.26	1.38	1.50	1.89	2.13
F	0.49	0.55	0.62	0.81	0.94	1.15	1.28	1.40	1.71	1.96
G	0.10	0.10	0.11	0.11	0.11	0.14	0.14	0.14	0.14	0.14
Y ±1°	12°	12°	12°	15°	15°	15°	15°	15°	15°	15°
H Ref.	0.37	0.37	0.41	0.47	0.53	0.61	0.61	0.61	0.61	0.61
O-Ring (mm)	8.92x1.83	10.52x1.83	11.9x1.98	16.36x2.21	19.18x2.46	23.47x2.95	26.59x2.95	29.74x2.95	37.47x3.00	43.7x3.00
Torque Sugerido (lb.ft)	15	19	27	55	77	133	166	210	225	288

MEDIDAS DE LAS ROSCAS BSPP (tipo de retención del anillo) ISO 1179-3

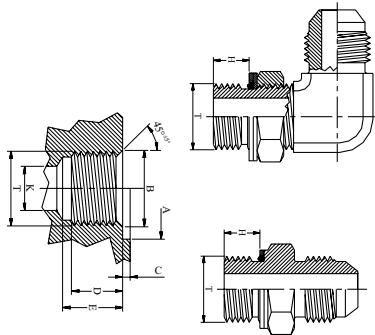

INFORMACIÓN TÉCNICA

Sellado con O-ring

- Si la superficie de la cara de la rosca esta mecanizada, las dimensiones A y C no necesitan ser aplicadas ya que los requerimientos de la superficie (Ra min 3,2) pueden evitar el daño al O-ring durante la instalación.
- C es la máxima profundidad recomendada para permitir un apropiado encaje del acople o la contratuerca.
- La superficie expuesta (dimensión B) debe ser alineada (0,2 mm) con las roscas
- El diámetro F debe ser concéntrico (0,1 mm) con las roscas
- La superficie en la longitud G necesita Ra 3,2 min para evitar daño en el O-ring durante la instalación.

Medida Rosca	1/8" -28	1/4" -19	3/8" -19	1/2" -14	3/4" -14	1" -11	1.1/4" -11	1.1/2" -11
T Nom.	0.383	0.518	0.656	0.825	1.041	1.309	1.650	1.882
C Max.	0.04	0.06	0.08	0.10	0.10	0.10	0.10	0.10
D Min.	0.31	0.47	0.47	0.55	0.63	0.71	0.79	0.87
E Min.	0.51	0.73	0.73	0.87	0.95	1.06	1.14	1.22
A Min.	0.67	0.83	0.96	1.18	1.46	1.81	2.13	2.40
B	0.39	0.52	0.66	0.83	1.07	1.31	1.65	1.89
H Ref.	0.26	0.35	0.37	0.45	0.53	0.59	0.63	0.63
O-Ring (mm)	7.97x1.88	10.80x2.62	13.95x2.62	17.86x2.62	23.47x2.62	29.70x3.53	37.70x3.53	44x3.53
Torque Sugerido (lb.ft)	15	26	52	74	140	221	243	295

MEDIDAS DE LAS ROSCAS METRICAS ISO 6149 tipo de retención O-Ring

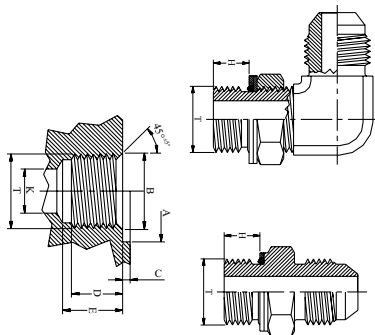

INFORMACIÓN TÉCNICA

Sellado con O-ring

- Si la superficie de la cara de la rosca esta mecanizada, las dimensiones A y C no necesitan ser aplicadas ya que los requerimientos de la superficie (Ra min 3,2) pueden evitar el daño al O-ring durante la instalación.
- C es la máxima profundidad recomendada para permitir un apropiado encaje del acople o la contratuerca.
- La superficie expuesta (dimensión B) debe ser alineada (0,2 mm) con las roscas
- El diámetro F debe ser concéntrico (0,1 mm) con las roscas
- La superficie en la longitud G necesita Ra 3,2 min para evitar daño en el O-ring durante la instalación.

Medida Rosca	10 x 1	12 x 1.5	14 x 1.5	16 x 1.5	18 x 1.5	20 x 1.5	22 x 1.5	26 x 1.5	27 x 2	33 x 2	42 x 2	48 x 2
T Nom.	0.39	0.47	0.55	0.63	0.71	0.79	0.87	1.02	1.06	1.30	1.65	1.89
C Max.	0.04	0.06	0.06	0.06	0.08	0.08	0.10	0.10	0.10	0.10	0.10	0.10
D Min.	0.31	0.47	0.47	0.47	0.47	0.55	0.55	0.63	0.63	0.71	0.79	0.87
F	0.53	0.73	0.73	0.73	0.73	0.81	0.81	0.89	0.95	1.02	1.10	1.18
G	0.63	0.79	0.85	0.95	1.06	1.18	1.26	1.42	1.46	1.77	2.17	2.44
Y 1°	0.39	0.47	0.55	0.63	0.71	0.79	0.87	1.02	1.06	1.30	1.65	1.89
H Ref.	0.31	0.35	0.35	0.41	0.47	0.47	0.49	0.49	0.57	0.57	0.59	0.69
O-Ring (mm)	8.1x1.6	9.3x2.2	11.3x2.2	13.3x2.2	15.3x2.2	17.3x2.2	19.3x2.2	23.6x2.9	23.6x2.9	29.6x2.9	38.6x2.9	44.6x2.9
Torque Sugerido (lb.ft)	15	26	33	41	52	59	74	125	125	228	243	302

MEDIDAS DE LAS ROSCAS BSPT- ISO 7

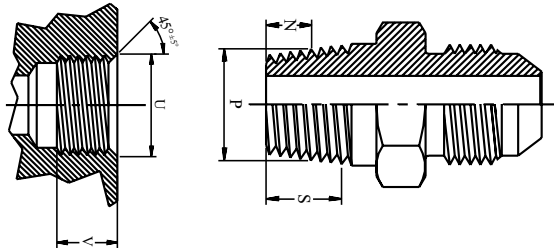

INFORMACIÓN TÉCNICA

El Sellado se obtiene acoplando la rosca paralela hembra (puerto) con el macho cónico (adaptador).

Medida Rosca	1/8" -28	1/4" -19	3/8" -19	1/2" -14	3/4" -14	1" -11	1.1/4" -11	1.1/2" -11
V Min.	0.22	0.33	0.33	0.41	0.51	0.57	0.67	0.67
U	0.38	0.52	0.66	0.82	1.04	1.31	1.65	1.88
N	0.16	0.24	0.25	0.32	0.37	0.41	0.50	0.50
Rosca de Trabajo	0.26	0.38	0.40	0.52	0.57	0.66	0.75	0.75

MEDIDAS DE LAS ROSCAS NPTF – SAE J 476

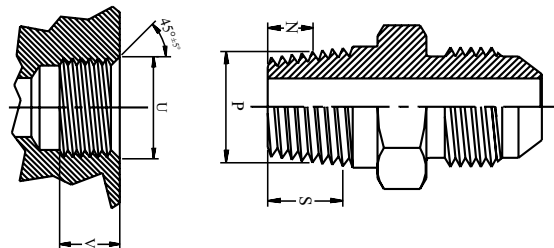

INFORMACIÓN TÉCNICA

La estanqueidad se logra por el emparejamiento de los hilos en las roscas macho y hembra (deformación de las crestas).

No se recomienda una frecuente conexión y desconexión por la deformación que se pueda su citar.

Medida Rosca	1/8" -27	1/4" -18	3/8" -18	1/2" -14	3/4" -14	1" -11.5	1.1/4" -11.5	1.1/2" -11.5
V Min.	0.31	0.45	0.46	0.61	0.63	0.75	0.77	0.77
U Ref.	0.40	0.53	0.67	0.83	1.04	1.30	1.65	1.89
N	0.16	0.23	0.24	0.32	0.34	0.40	0.42	0.42
P	0.37	0.49	0.63	0.77	0.99	1.24	1.58	1.82
Rosca de Trabajo	0.30	0.46	0.46	0.61	0.62	0.77	0.80	0.81

MEDIDA FINAL DEL HILO

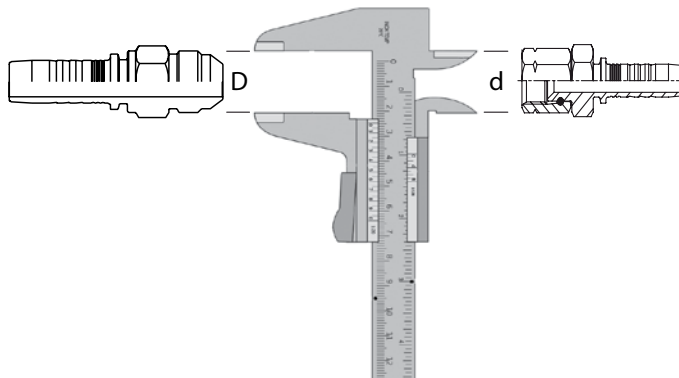

Para identificar la medida de la cuerda, mida el diámetro exterior de la cuerda en el macho O.D. o el diámetro interior de la cuerda en la hembra I.D. luego mirando la columna mm obtendrá el tamaño correspondiente de la rosca.

MACHO D.E.	mm	HEMBRA D.I.
------------	----	-------------

	0.33	3/8" -24 UNF
	0.34	1/8" -28 GAS
	0.36	1/8" -27 NPSM
3/8" -24 UNF	0.37	
1/8" -28 GAS	0.38	
M10 x 1	0.39	7/16" -20 UNF
1/8" -27 NPTF	0.41	
	0.41	M12 x 1.5
7/16" -20 UNF	0.43	
	0.45	1/2" -20 UNF
	0.46	1/4" -19 GAS
M12 x 1.5	0.47	
	0.48	1/4" -18 NPSM
1/2" -20 UNF	0.49	M14 x 1.5
1/4" -19 GAS	0.51	9/16" -18 UNF
1/4" -18 NPTF	0.55	
M14 x 1.5	0.55	
9/16" -18 UNF	0.56	
	0.57	M16 x 1.5
	0.57	5/8" -18 UNF
	0.59	3/8" -19 GAS
	0.61	3/8" -18 NPSM
5/8" -18 UNF	0.62	
M16 x 1.5	0.63	11/16" -16 UN
	0.65	M18 x 1.5
3/8" -19 GAS	0.65	
3/8" -18 NPTF	0.68	
11/16" -16 UN	0.69	3/4" -16 UNF
M18 x 1.5	0.71	
	0.73	M20 x 1.5
	0.74	1/2" -14 GAS
3/4" -16 UNF	0.75	13/16" -16 UN

MACHO D.E.	mm	HEMBRA D.I.
------------	----	-------------

	0.76	1/2" - 14 NPSM
M20 x 1.5	0.79	
	0.80	7/8" -14 UNF
13/16" -16 UN	0.81	M22 x 1.5
1/2" -14 GAS	0.82	
	0.83	5/8" -14 GAS
1/2" -14 NPTF	0.85	
M22 x 1.5	0.87	
7/8" -14 UNF	0.87	
	0.89	M24 x 1.5
5/8" -14 GAS	0.90	
	0.94	1" -14 UNS
M24 x 1.5	0.94	
	0.96	M26 x 1.5
	0.97	3/4" -14 GAS-NPSM
	0.98	1.1/16" -12 UN
	0.98	M27 x 2
1" -14 UNS	1.00	
M26 x 1.5	1.02	
3/4" -14 GAS	1.04	
1.1/16" -12 UN	1.05	
3/4" -14 NPTF	1.06	
M27 x 2	1.06	
	1.10	1.3/16" -12 UN
	1.10	M30 x 2
M30 x 2	1.18	
1.3/16" -12 UN	1.19	
	1.21	1" -11.5 NPSM
	1.22	1" -11 GAS
	1.22	M33 x 2
	1.23	1.5/16" -12 UN
M33 x 2	1.30	

MACHO D.E.	mm	HEMBRA D.I.
------------	----	-------------

1" -11 GAS	1.31	
1.5/16" -12UN	1.31	
1" -11.5 NPTF	1.33	
	1.34	M36 x 2
M36 x 2	1.42	
	1.54	1.5/8" -12 UN
	1.55	1.1/4" -11.5 NPSM
	1.56	1.1/4" -11 GAS
	1.57	M42 x 2
1.5/8" -12 UN	1.62	
1.1/4" -11 GAS	1.64	
M42 x 2	1.65	
1.1/4" -11.5 NPTF	1.67	
	1.69	M45 x 2
M45 x 2	1.77	
	1.78	1.1/2" -11 GAS
	1.79	1.1/2" -11.5 NPSM
	1.80	1.7/8" -12 UN
	1.81	M48 x 2
1.7/8" -12 UN	1.87	
1.1/2" -11 GAS	1.88	
M48 x 2	1.89	
1.1/2" -11.5 NPTF	1.91	
	1.92	2" -12 UN
	1.97	M52 x 2
2" -12 UN	2.00	
M52 x 2	2.05	
	2.24	2" -11 GAS
2" -11 GAS	2.34	
2" -11.5 NPTF	2.39	
	2.41	2.1/2" -12 UN
2.1/2" -12 UN	2.49	